



B2P OPERATING MANUAL

TABLE OF CONTENTS

Introduction.....	p. 2
Features	p. 2
Description.....	p. 3
Theory of Operation	p. 3
Installation	p. 4
Electrical Connections	p. 5
Options.....	p. 6
Warranty	p. 6
Specifications	p. 7
Troubleshooting	p. 8
Ordering Codes.....	p. 9
Wiring Diagrams	p. 10 - 16
Dimensional drawings	p. 17 - 23



Avatar Instruments, Inc.
Phone: (610) 543-5155

577 Abbott Drive
Fax: (610) 543-5255

Broomall, PA 19008
www.scrpower.com

INTRODUCTION

Congratulations on your purchase of an Avatar B2P series power control. This manual was designed to assist you in installing, operating and maintaining your new power control in a safe manner. Upon reading and following the instructions in this manual, you will be rewarded many years of trouble free service from your new B2P. If reading manuals is not for you, it is essential that you at least read the captions followed by the safety warnings; they are located through out the manual and are very easy to identify.



indicates important installation, operating, servicing instructions

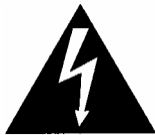

indicates dangerous voltage present and risk of electric shock

FEATURES

- compact and light weight
- I²T sub cycle fusing standard
- 100 % solid state circuitry
- over-rated dual SCR power modules
- thermostat std on fan cooled units
- over-sized heat sink
- full power ratings up to 50°C (122°F) ambient temperature
- optically isolated 4-20 mA input standard
- electrically isolated chassis and heat sinks
- MOV protection on all power SCR's
- SanRex, SemiKron, International Rectifier and Fairchild semiconductors
- double sided FR4 VO-94 rated glass epoxy PCB's

DESCRIPTION

The B2P is a proportional, infinitely variable power controller capable of delivering 0-97% of the applied line voltage to inductive loads. The B2P is specifically designed to drive transformers, but will drive resistive loads too. This is accomplished by phase angle firing a pair of inversely connected SCR's. Modular construction allows for simple and solderless field serviceability. There are four field replaceable items:

- printed circuit board
- fuse
- dual SCR package
- MOV (metal oxide varistor)

THEORY OF OPERATION

The standard input signal (4-20mA) is applied to the large blue input terminal block, processed and fed to an optical coupler. The output of the opto coupler controls the pulse generator which drives a pair of opto couplers. Each opto coupler is in series with its own isolated SCR drive power supply providing drive to a pair of inversely connected SCR's. To obtain superior linearity, the line voltage is monitored and optically fed back to the input stage of the controller. An I2T fuse connected in series with the SCR's provides over current protection in the event of external wiring shorts, and or too large of a heater load. Additionally, a MOV (metal oxide varistor) is connected in parallel with the SCR's, providing voltage spike protection to the controller.

PHASE ANGLE FIRED

These controls proportionally turn on a percentage of each power line half cycle. This gives smooth, infinitely variable application of power to the heaters. Imagine a light dimmer and how it provides power to a light bulb. This method will provide the most precise control of heaters. Phase angle fired SCR's will respond the fastest to load change and provide maximum heater life. It is the most precise method of control. Phase angle firing can increase heater *life up to seven times depending on heater type*. Phase angle firing also allows options such as soft start, voltage limit and current limit. These options are not available with any other means of control.

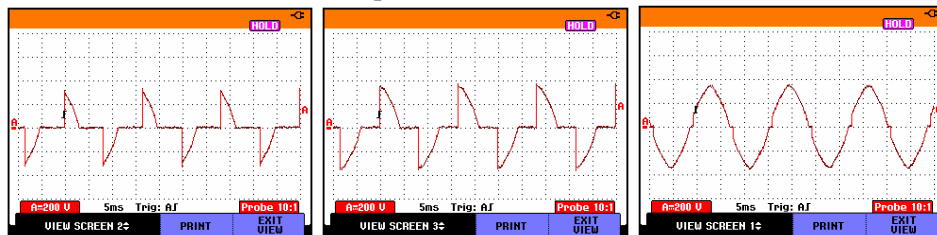

25% output 60V RMS

50% output 120V RMS

99.5% output 238.8V RMS

INSTALLATION



WARNING: FIRE HAZARD!! Even the best electronic components CAN FAIL SHORTED, KEEPING FULL POWER ON! Provide a completely SEPARATE (redundant) OVER TEMPERATURE SHUTDOWN MEANS to switch power off if safe temperature is exceeded.



WARNING: HIGH VOLTAGE!! This control must be installed in a GROUNDED enclosure. Provide a safety interlock on door to remove power before gaining access to device.



This controller must be installed by a qualified electrician in accordance with any and all local and national electric codes including NEC and any other applicable codes.

First things first, do you have the proper controller for your application? Check the Avatar serial tag and verify the correct voltage/ ampere ratings and input control signal for your application.

After verifying you have the proper controller, the next most important item is adequate cooling/ ventilation. All Avatar power controllers are rated to deliver full power to their respective load(s) at an ambient temperature not to exceed 50 degrees C. Use this formula to calculate the minimum size enclosure required.

1.2 VOLTS X MAXIMUM HEATER CURRENT = TOTAL WATTS DISSIPATED

example: 1.2 x 200 amps = 240 watts that the power controller must dissipate

Heat is the worst enemy to any electrical device, including power controllers. Orient heat sink fins in a vertical position, providing adequate air flow above and below unit. The cooler the unit operates, the longer it will provide seamless, reliable service. Mounting direction on fan cooled units is not critical.

The dryer and cleaner, the better! Over time, a combination of moisture and contaminants will lead to failure due to corrosion and insulation breakdown (arcing and sparking). If the controller absolutely must be installed in a harsh and corrosive environment, it is recommended that an air conditioned NEMA 4X or similar type of environmentally sealing enclosure be used during installation.

ELECTRICAL CONNECTIONS



Again, this work must be performed by a qualified electrician and in accordance with any and all local and national codes that may apply. Please refer to the wiring diagrams (pgs. 10 - 16).



To reduce the risk of electrocution, TURN ALL POWER OFF to wires that will be connected to the power control before making any connections. The standard B2P controller over 150 amps is not provided with a cover; therefore it is highly recommended the controller be installed in a metal enclosure for protection against electrocution. 1200 amp controller heat sinks **are on line voltage!!**

AC POWER INPUT:

Power input (AC MAINS) is connected to lugs labeled "LINE 1" and "LINE 2". (see fig. 1 for correct wire size and torque specifications)

LOAD CONNECTION:

Load connections are equally simple; connect the load/ heater to lugs labeled "HTR 1" and "HTR 2". (see fig. 1 for correct wire size and torque specifications)

Check heater resistance to insure heater current will not exceed fuse ratings. Controllers DO NOT blow fuses - excess heater current does. Check for heater wiring shorts, bad connections, etc. prior to applying power, shorted load connections will instantly blow expensive fuses.

INPUT CONTROL SIGNAL:

Connect the control signal to the blue terminal block labeled "4-20mA INPUT" observing proper polarity (positive to "+" and negative to "-"). Fan cooled units come standard with a thermostat switch mounted to the heat sink. The thermostat can be used for triggering alarms, aux. fans, etc. or wired in series with the input control signal providing over temperature protection. See wiring diagrams (pgs. 12, 13 and 14).

THERMOSTAT for FAN FAILURE:

On all Avatar SCR Controls 150 Amps and above, fans are used to cool the SCR heat sinks. Avatar mounts a Snap-disc thermostat to the heat sink. If the fan fails, air is blocked or a safe ambient temperature is exceeded, the thermostat will activate. This thermostat can be used to break 4-20mA input signal, trigger alarms or shut down a power contactor. See wiring diagram for thermostat wiring.

OPTIONS

SOFT START: All B2P SCR power controllers have a 500ms soft start built into them. This is to remove the inrush current and transient inherent with a transformer primary. The soft start is made for applications where heaters have inrush currents. For use with Tungsten (T-3), Molybdenum or Graphite heaters. This option is designed to ramp power from 0-100% over a fixed time period. This time is 2 (S02), 5 (S05), 10 (S10) or 20 (S20) seconds depending on option ordered. If the input signal goes to 4mA (0%), the soft start will engage for the full length of time when the mA signal is reactivated. The soft start option will also restart if line voltage is interrupted to the SCR. Extra DV/DT Suppression board and Voltage Limit included with option.

VOLTAGE LIMIT: The voltage limit option (VL) is used to reduce the maximum output voltage applied to the heaters. The adjustment is located on the trigger board close to the 4-20mA input signal terminal. It is marked as "V-LIM". To set the voltage limit, connect a volt meter across HEATER 1 & HEATER 2. THERE MUST BE A LOAD CONNECTED FOR SCR TO FIRE. With a full 20mA input signal, turn potentiometer CCW to reduce maximum output voltage to desired level. This option comes as standard on soft start option.

CURRENT LIMIT: The CL & CLP option is designed to monitor and limit the output current of the SCR. Avatar Instruments provides the current transformer(s) (CT) and hard wires them to the trigger board. Simply put the LINE 1 input wire through the current transformer located next to the LINE 1 set screw lug.

Adjusting current limit: To set the current limit, connect an Amp-probe onto the HEATER 1 output wire. THERE MUST BE A LOAD CONNECTED FOR SCR TO FIRE. On SCR's with "-CL" option, the potentiometer adjustment is located on the PCB. With a full 20mA input signal, turn potentiometer counter clockwise (CCW) to reduce maximum output voltage to desired level. The "-CLP" option has a panel-mount potentiometer (3/8"), knob & scale. Turn the potentiometer counter clockwise (CCW) or lower on the 0-100 scale, to reduce maximum power output.

For manual control use Avatar model **MAP**. Isolated Potentiometer 4-20mA signal card.

For LINEAR 0-5 or 0-10 VDC Analog Signal use Avatar MAI milliamp interface card.

MAI-05V takes a 0-5VDC signal input and outputs 4-20mA.

MAI-10V takes a 0-10VDC signal input and outputs 4-20mA.

For 2nd Leg Fusing add "-2nd" to part number. All fuses come mounted to chassis w/lugs. Higher Amp Fuse come with block & lugs.

WARRANTY

All Avatar Instruments products carry a full **five year**, warranty from date of purchase, parts and labor warranty against component failure and defects in workmanship. In the event your controller fails to perform properly, **contact Avatar to obtain a return authorization number**. Controllers sent to Avatar for warranty service that have no apparent defect will be treated as a standard repair and a \$50.00 charge will be applied. Avatar will repair or replace any unit that failed due to defective parts or assembly. This warranty DOES NOT cover damage due to shipping, abuse, misapplication or operation beyond specified rating. Furthermore, fuses and improperly fused SCR's are NOT COVERED by this warranty. Avatar is not responsible for any subsequent or other damage experienced in use of this device.

SPECIFICATIONS

INPUT VOLTAGE: see model description
 OUTPUT VOLTAGE: 0-97% of input voltage
 CURRENT CAPACITY: see model description
 CONTROL SIGNAL: 4-20mA @ 6 volts DC, 300 Ohms
 LINEARITY: < 5% deviation
 RESPONSE TIME: <12mS (std unit, non soft start)
 COOLING: 30-100 amps convection
 150-1200 amps fan (120VAC)
 THERMOSTAT: 190 °F (fan cooled units only)
 POWER DISSIPATION (Watts): 1.2 x maximum current
 DIMENSIONS: see dimensional drawings
 WEIGHT: **NET** **SHIPPING**
 30 amp..... 3.5 lbs. 4 lbs.
 40-100 amp..... 6 lbs. 8 lbs.
 150-225 amp 14 lbs. 23 lbs.
 250-600 amp 22 lbs. 31 lbs.
 1200 amp..... 55 lbs. 80 lbs.

Wire Gauge and Torque Specifications for 90°C Temp Wire			
Power Control Maximum Current Rating/ Circuit	Copper Wire Only MINIMUM AWG	Wire Lug Torque Spec. (lbs./in.)	Lug Size
30A	10AWG	35	10 AWG
40A	8AWG	40	1/0 - 14
60A	6AWG	45	1/0 - 14
80A	4AWG	45	1/0 - 14
100A	3AWG	50	1/0 - 14
150A	1AWG	180	250MCM - 6
200A	3/0 AWG	250	250MCM - 6
225A	3/0 AWG	250	250MCM - 6
250A	4/0 AWG	250	250MCM - 6
350A	TWO: 4/0 AWG	250	TWO: 250MCM-6
600A	TWO: MCM 350	325	TWO: 600MCM-2
1200A	FOUR: MCM 350	375	FOUR: 600MCM-2

fig. 1

TROUBLESHOOTING

SYMPTOM	POSSIBLE CAUSE	POSSIBLE SOLUTION
Heater does not heat up	no power to B2P	verify correct input voltage between "LINE" lugs on B2P.
	blown fuse in B2P	check for shorted or grounded heater, oversize heater, only then replace fuse. For tungsten Lamps order soft start option.
	blown fuse on B2P-S-	as above plus - cold lamp switched on after start, loose connection to cold lamp.
	check voltage limit adjustment on B2P with soft start (B2P-S-)	If limit is set for minimum output (CCW), soft start could take over 60 seconds worst case.
	no control signal to B2P	verify 4-20mA signal is hooked up correctly (positive to "+" and negative to "-") on the source and A1P. verify signal presence by placing a milliamp meter in SERIES with one of the control wires.
	defective heater	check for output voltage between the "HTR" terminals. If voltage is present, check wiring to the heater(s) and the actual heater(s).
Heater is on full all the time	incorrect source signal	verify 4-20mA signal varies from 4-20mA.
	shorted SCR's in B2P	with power applied, measure voltage drop across "LINE 1" and "HTR 1", if voltage reading is less than one volt, the SCR's are damaged, using the same method, check LINE 2-HTR 2 and LINE 3.
Process will not stabilize - control signal oscillates	incorrect tuning of temperature controller, bad sensor location or lag	set proper rate, reset, and prop band on temperature control, speed up sensor.

B2P SERIES SCR POWER CONTROLLERS

ORDERING CODES

B2P - _____ - _____ - _____ - _____
 Voltage **Amperes** **Options** **Options**

VOLTAGE DESIGNATIONS

- (12) 120 VAC 50/60Hz
- (24) 208-240 VAC 50/60Hz
- (27) 277 VAC 50/60Hz
- (38) 380 VAC 50/60Hz
- (48) 480 VAC 50/60Hz
- (57) 575 VAC 50/60Hz
- (60) 600 VAC 50/60Hz

LOAD IN AMPS:

- 30, 40, 60, 80, 100, 150
- 200, 225, 250, 350, 600

OPTIONS:

Soft Start

- 2 Seconds (S02)
- 5 Seconds (S05)
- 10 Seconds (S10)
- 20 Seconds (S20)

Current Limit (CL)

(CLP) with panel mount potentiometer)

Voltage Limit

- Standard 1 turn PCB (VL)
- 25 turn PCB (VL25)

Example: B2P-24-60-S05-CL is a 240VAC, 60 Ampere SCR with 5 second soft start and current limit.

B2P Trigger Board

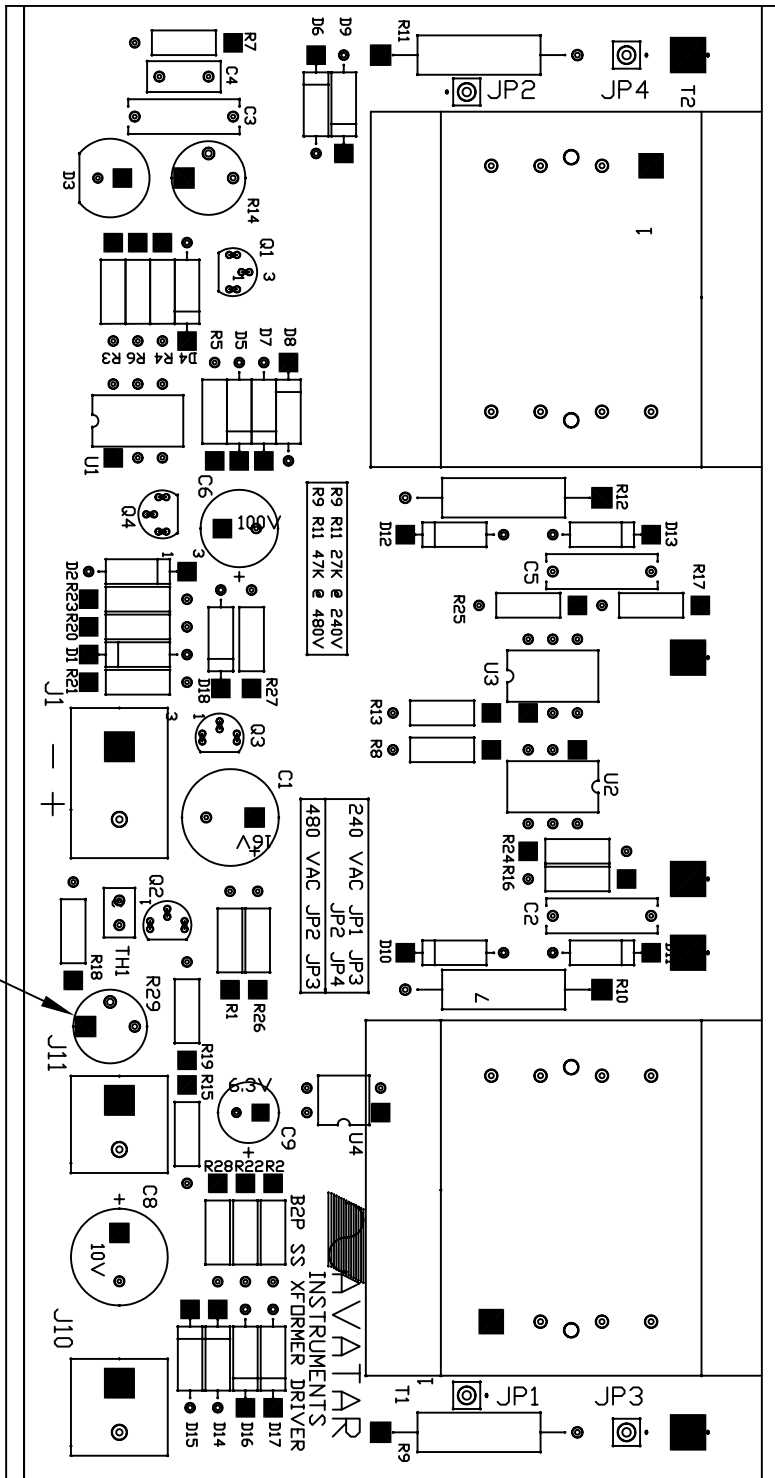

B2P WIRING DIAGRAM

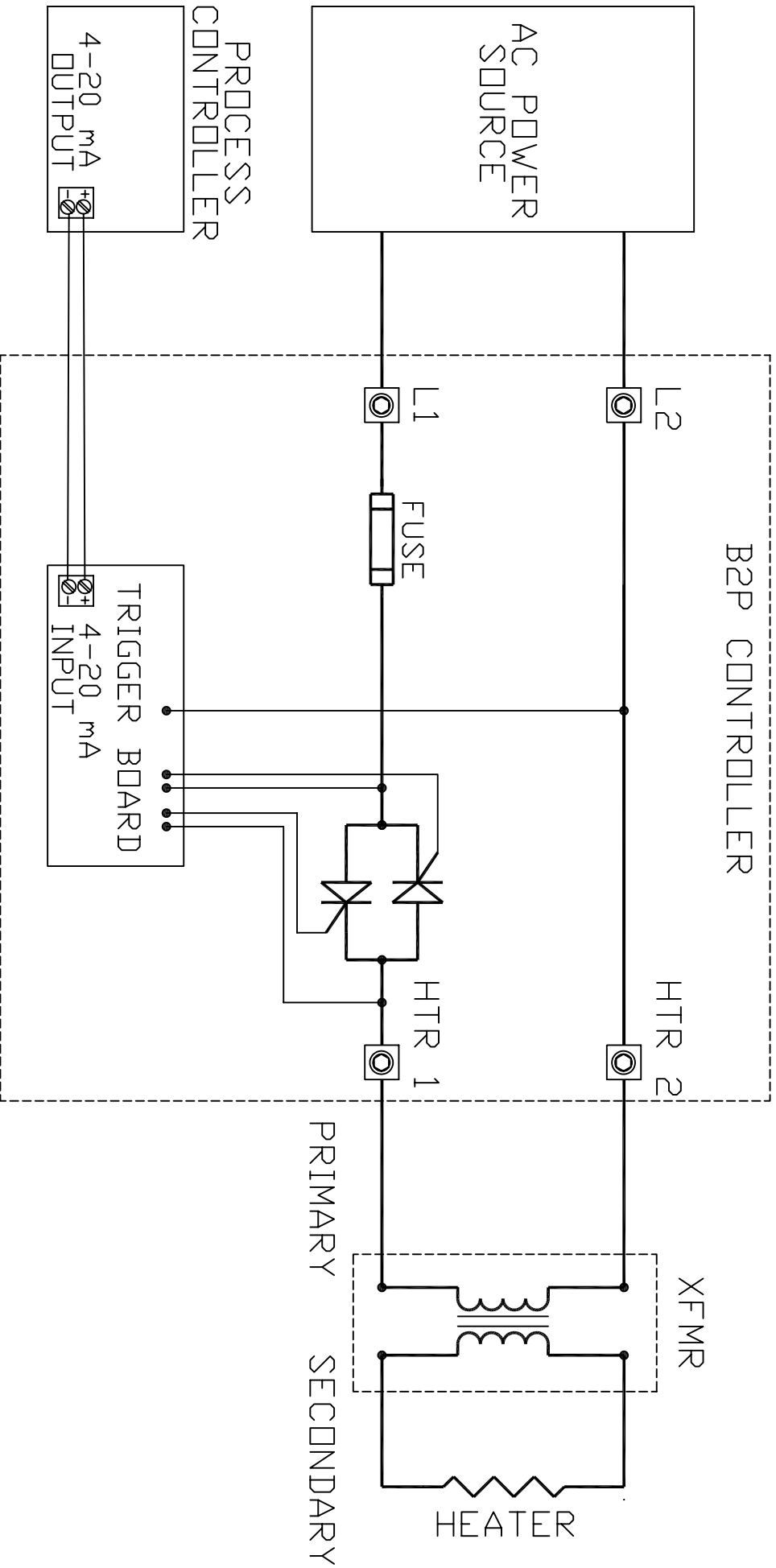

OVERTEMPERATURE THERMOSTAT WIRING DIAGRAMS

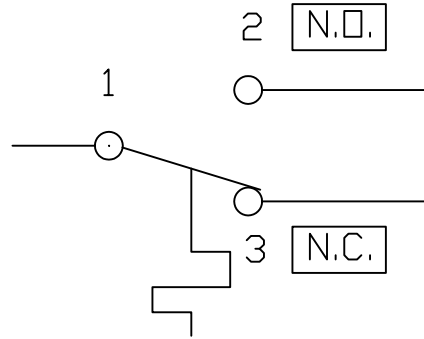
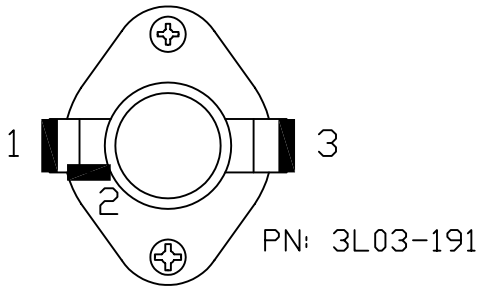

CONTACT RATINGS

1 & 2:
5.8A 120VAC
2.9A/240VAC

1 & 3:
10A/120VAC
5A/240VAC

OPEN: 190F
CLOSE: 170F

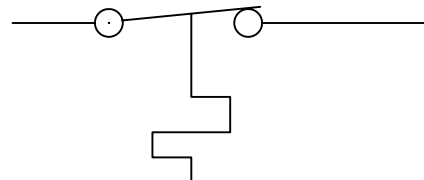
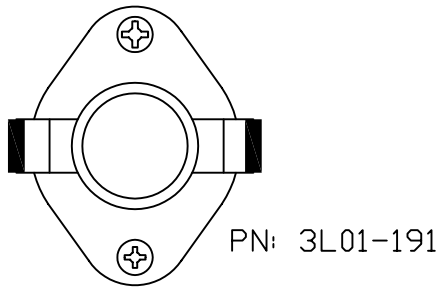

CONTACT RATING:
10A/120VAC
5A/240VAC

OPEN: 190F
CLOSE: 170F

FAN WIRING DIAGRAMS

100 thru 600 AMPS

TERMINAL TYPE 6.9

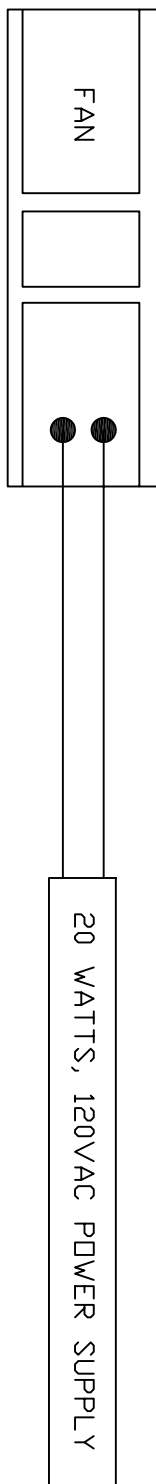

WARNING!
Fans MUST be ON when SCR power controller is on!
Power to fans must be applied before or coinciding with the turn on of line voltage to the SCR power controller. *Failure to do so will damage SCRs and other components.*

TERMINAL BLOCK

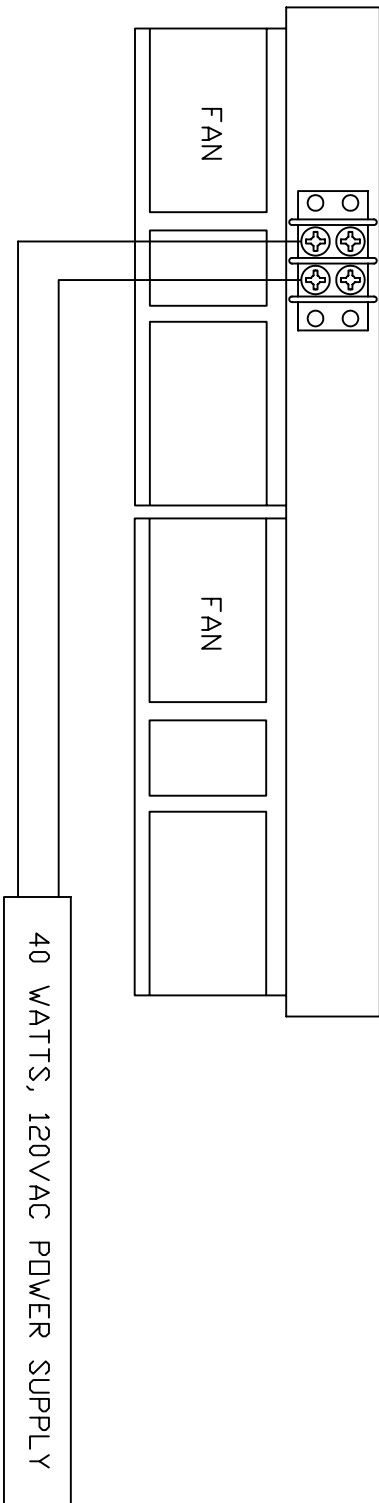

TERMINAL BLOCK

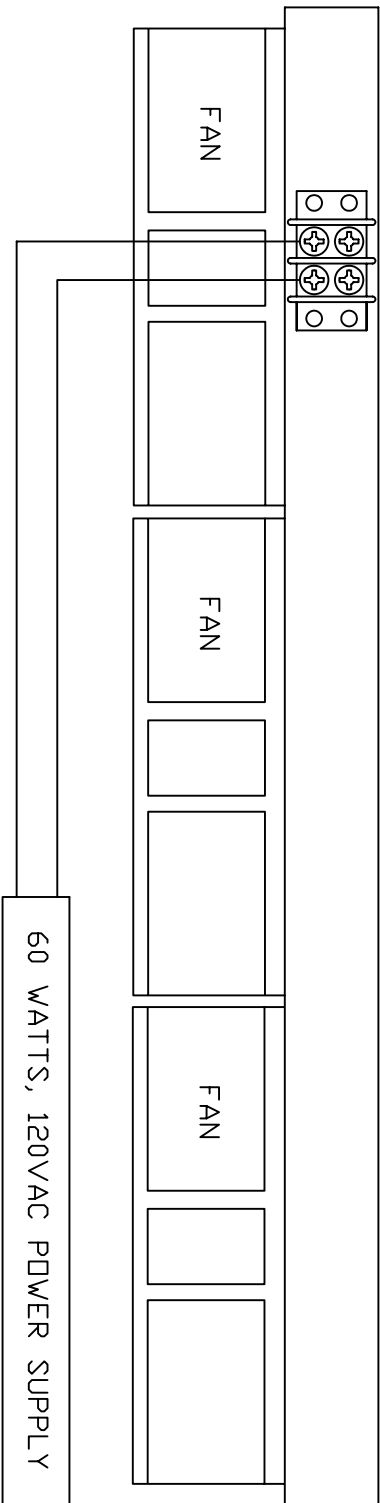

FAN WIRING DIAGRAMS 1200 AMPS

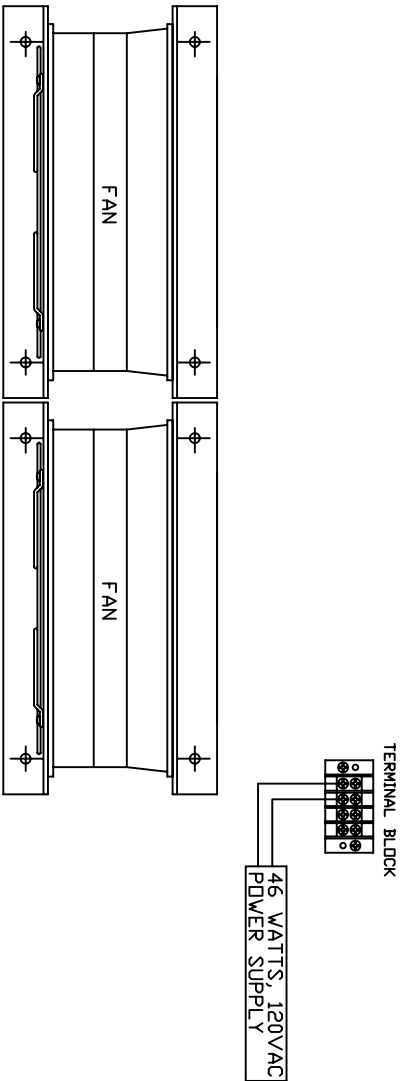
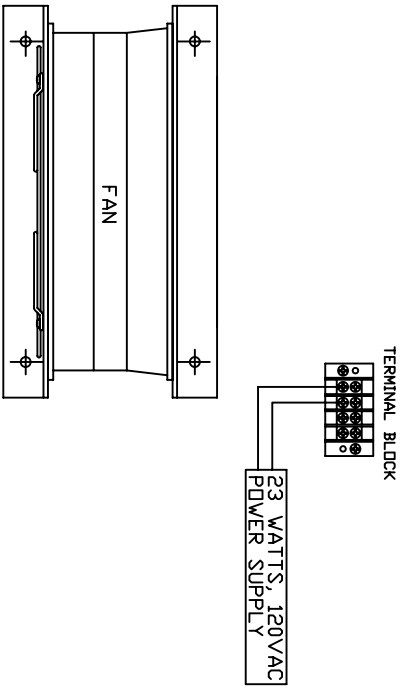

WARNING!
Fans **MUST** be ON when SCR power controller is on!
Power to fans must be applied before or coinciding with the turn on of line voltage to the SCR power controller. *Failure to do so will damage SCRs and other components.*

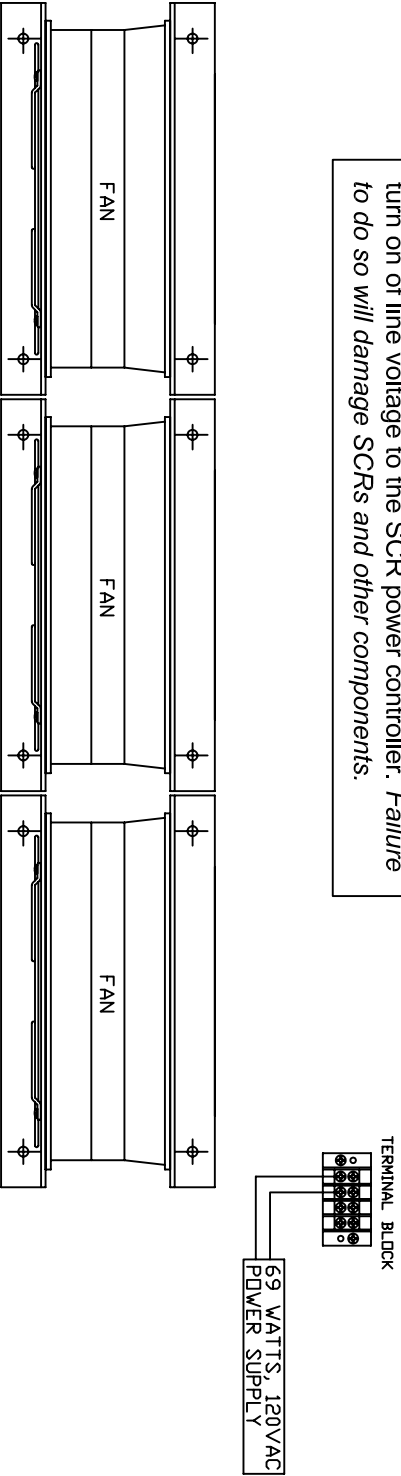

CURRENT LIMIT CARD WIRING DIAGRAMS

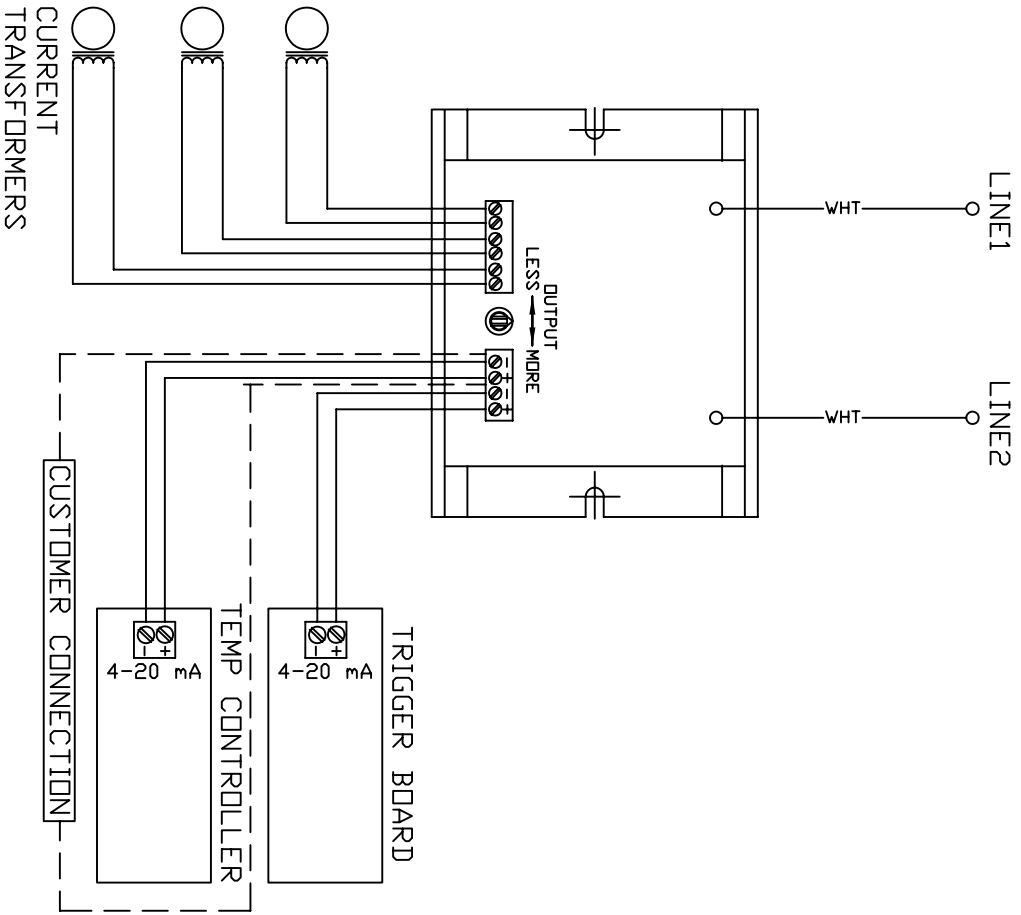

3 PHASE

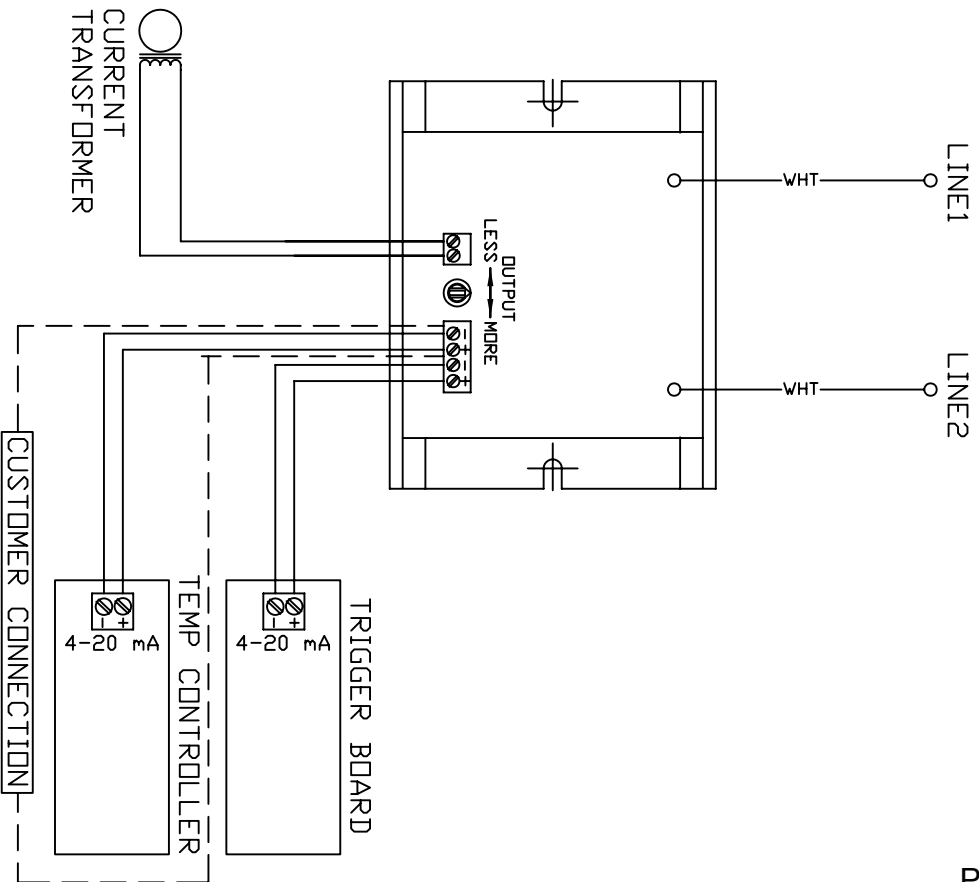

SINGLE PHASE

CURRENT TRANSFORMER INSTALLATION DETAIL

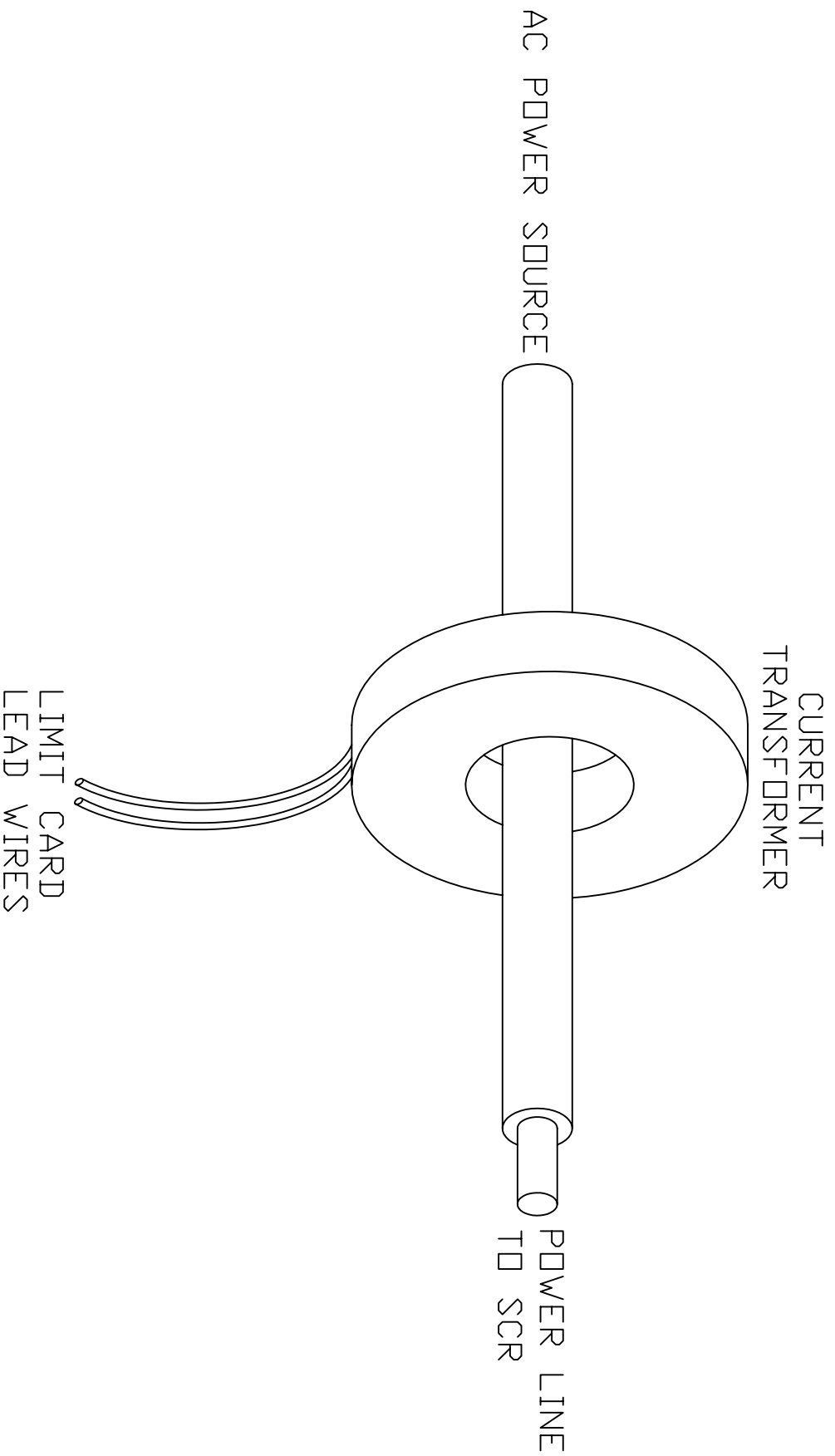

PHYSICAL DIMENSIONS CURRENT TRANSFORMERS

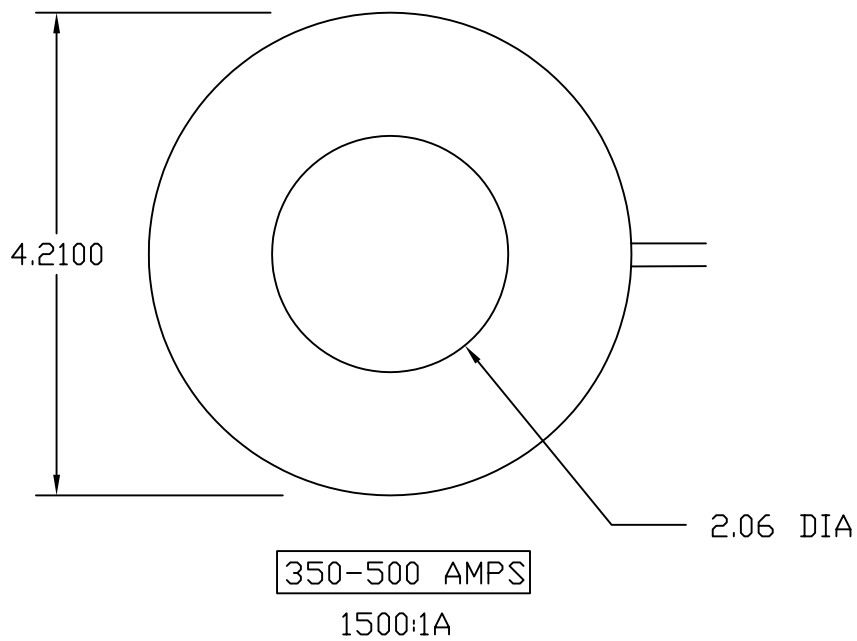
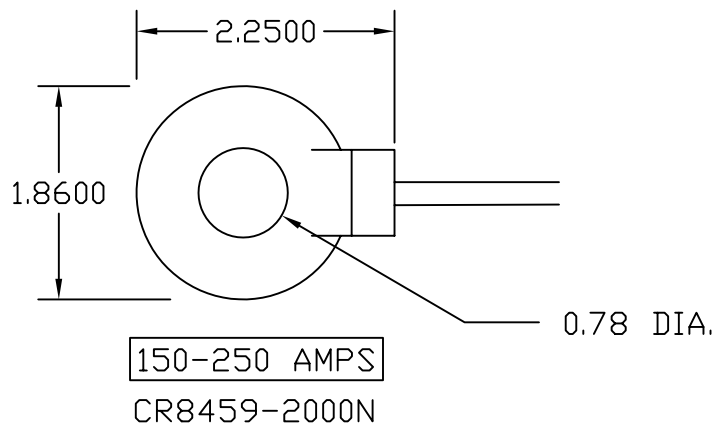
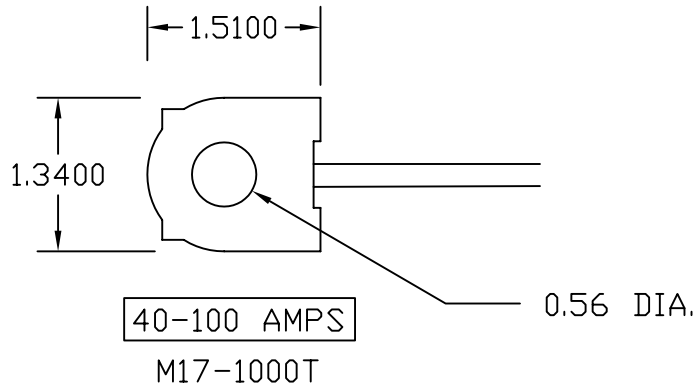
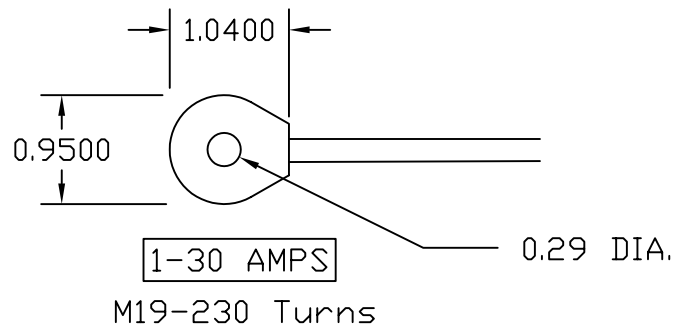

PHYSICAL DIMENSIONS

B2P - 40, 60, 80 & 100 AMP

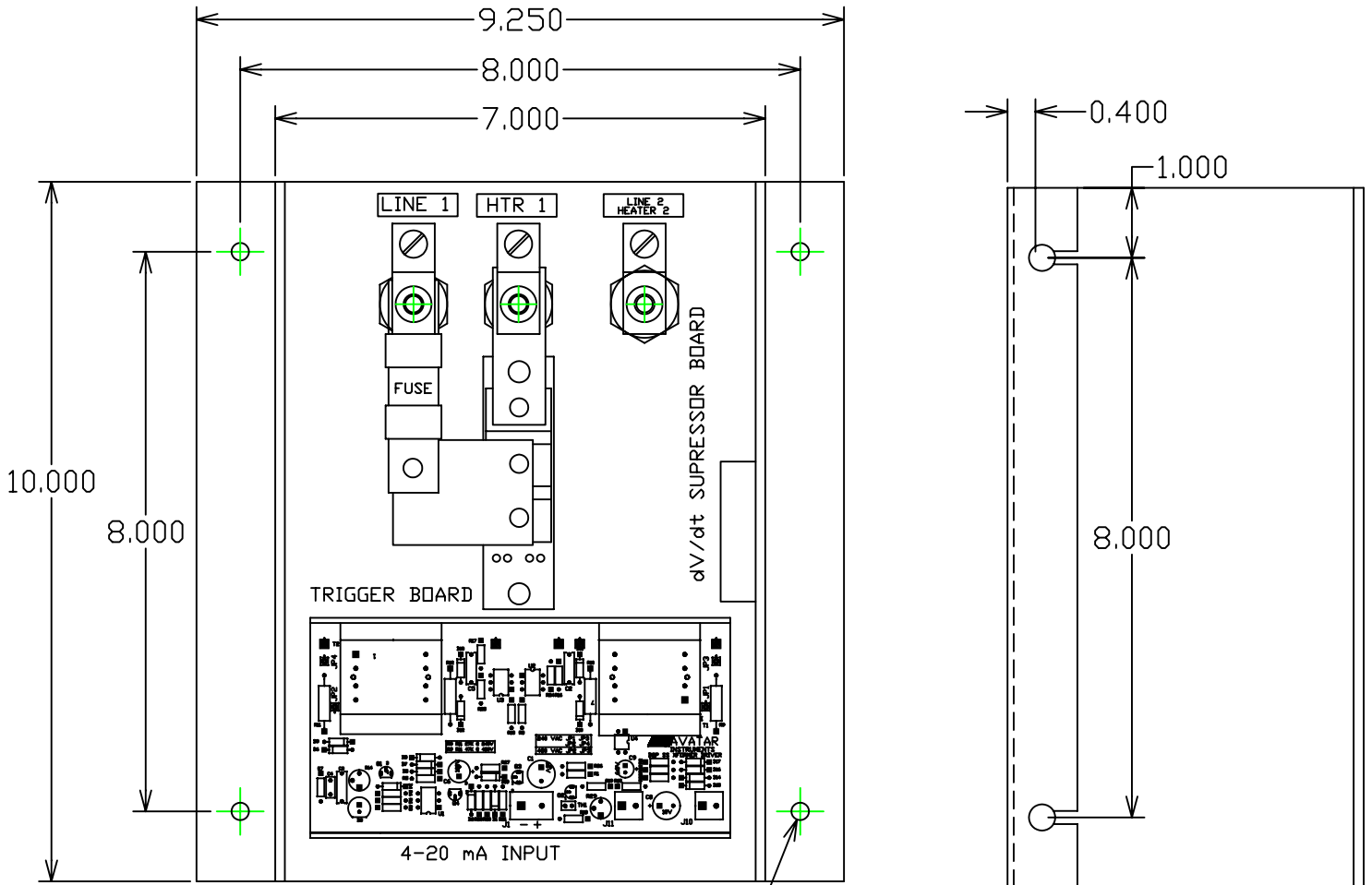

(4) MOUNTING HOLE DIAMETER 0.275"

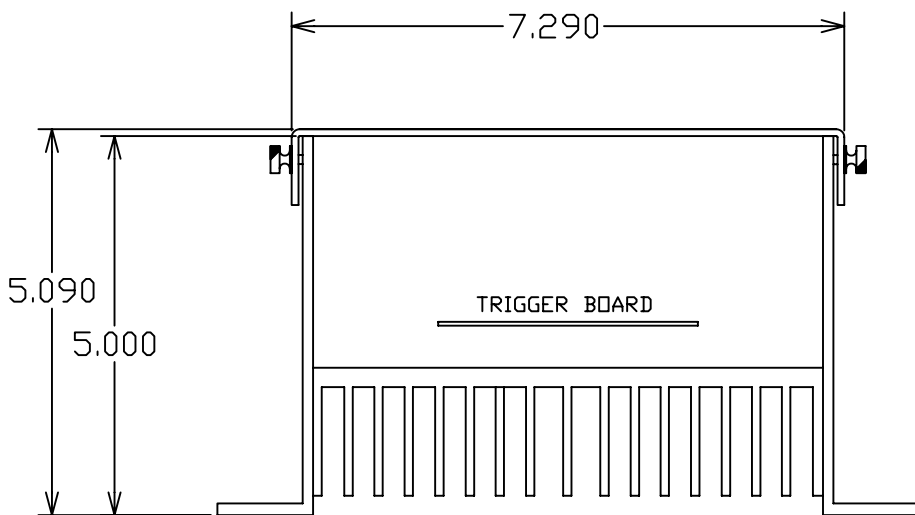

PHYSICAL DIMENSIONS

B2P - 150, 200 & 225 AMP

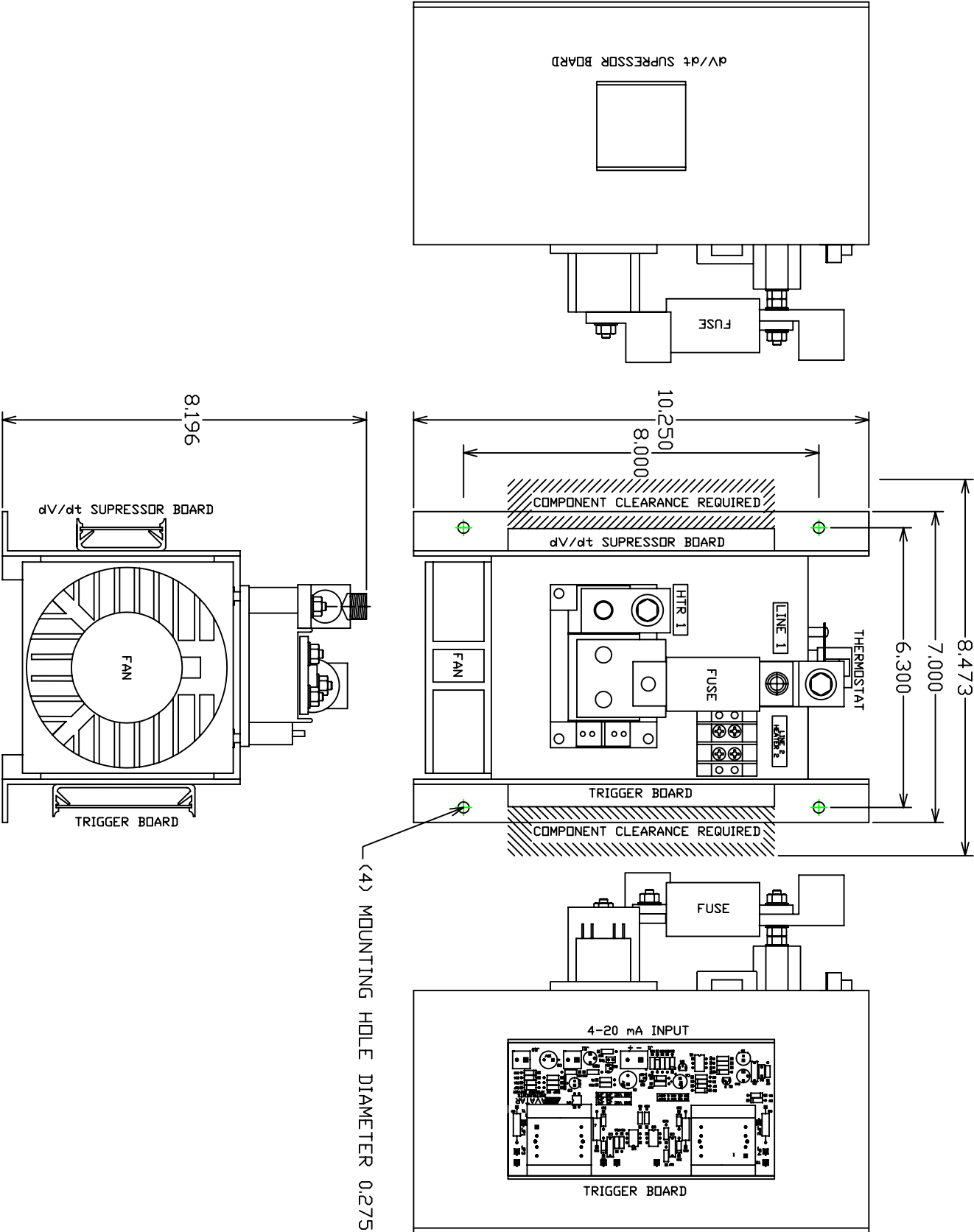

PHYSICAL DIMENSIONS B2P - 250 AMP

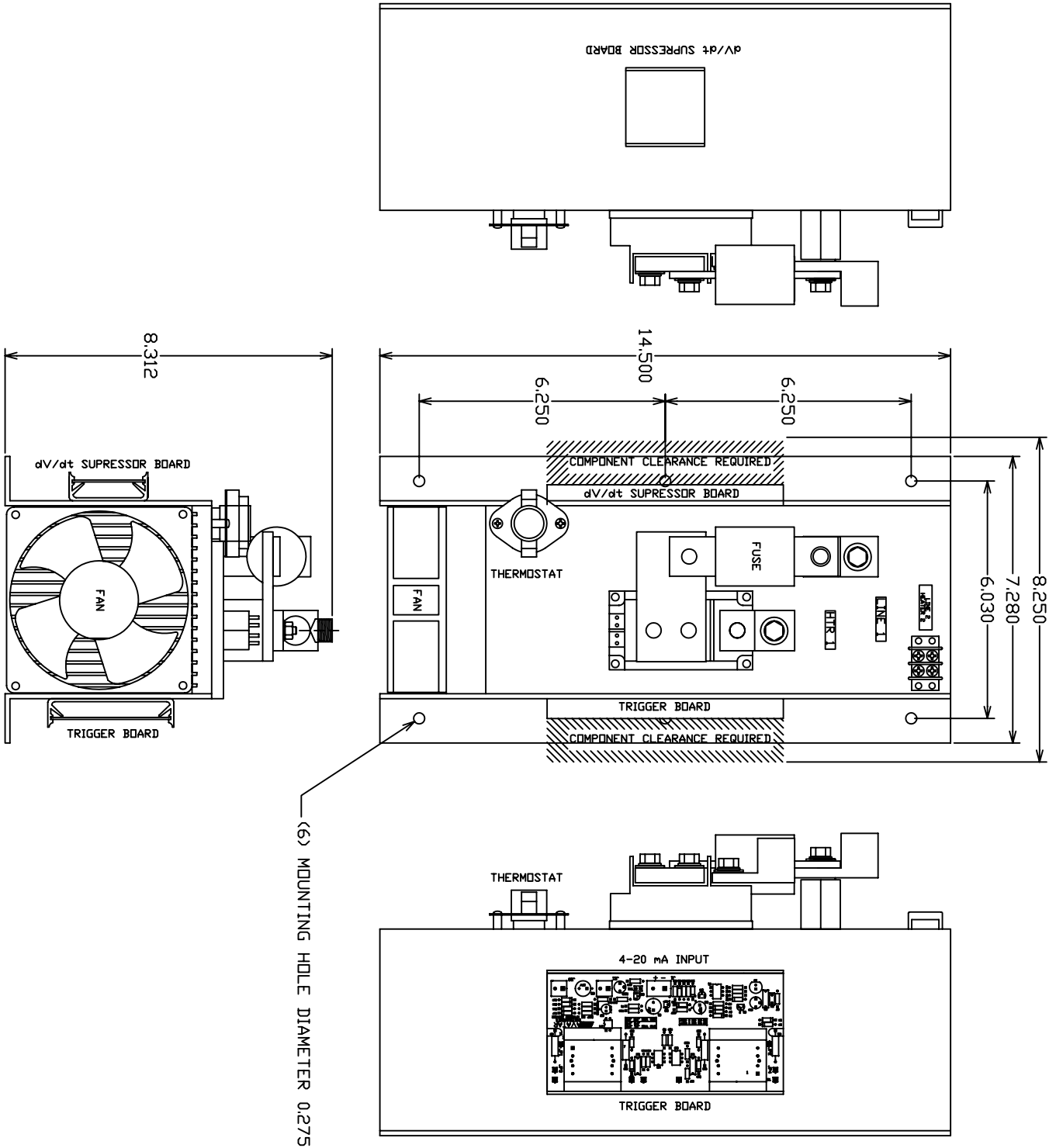

PHYSICAL DIMENSIONS B2P - 350 AMP

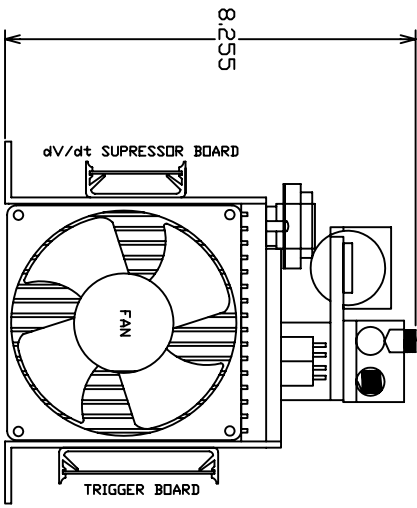
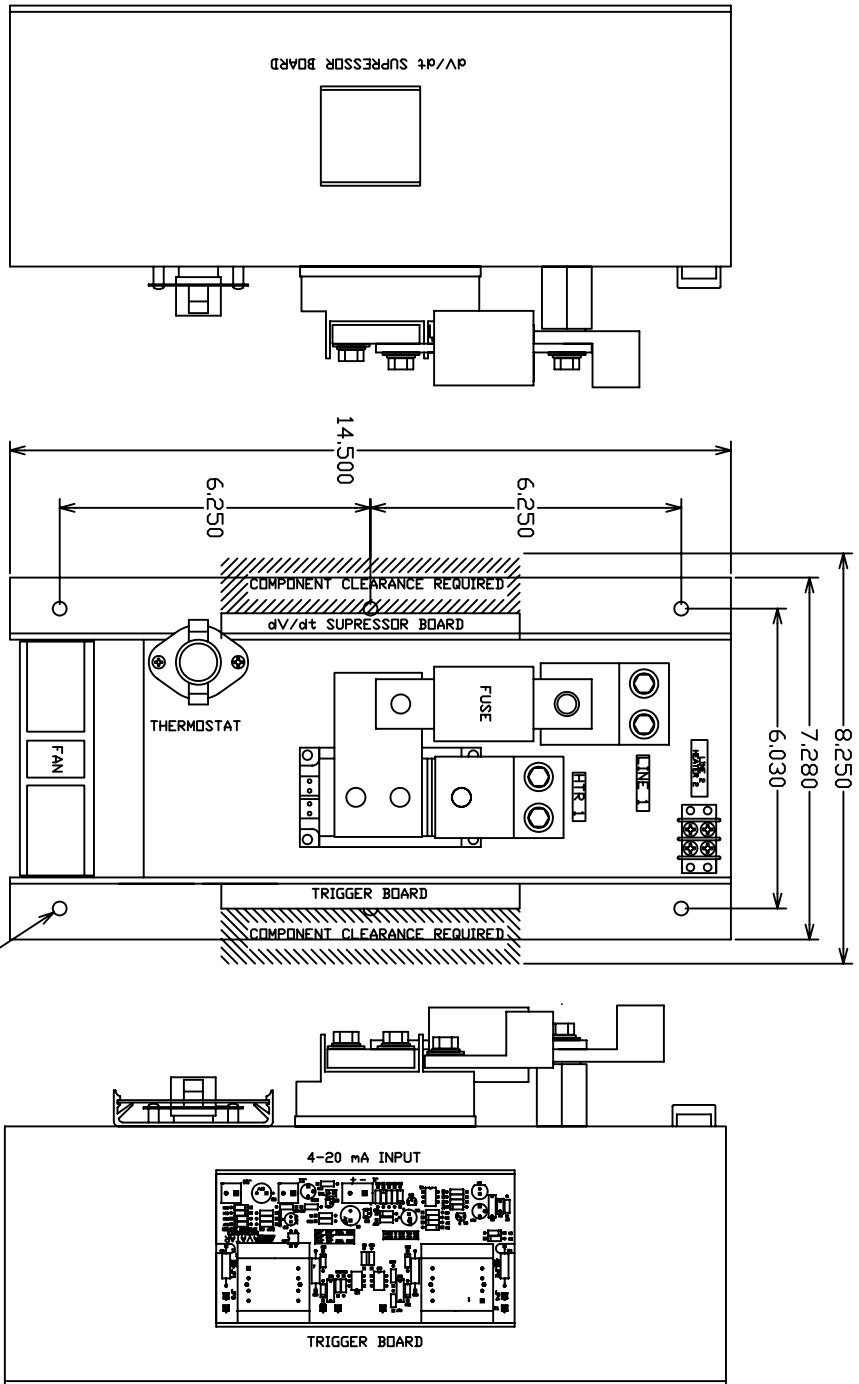

(6) MOUNTING HOLE DIAMETER 0.275"

PHYSICAL DIMENSIONS

B2P - 600 AMP

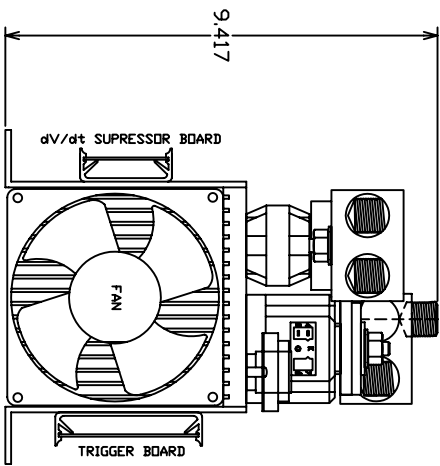
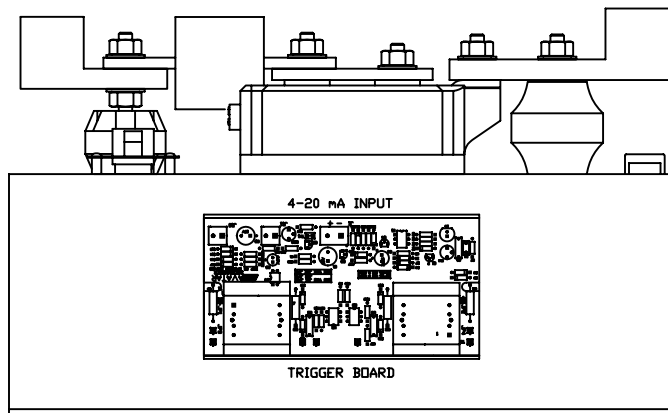
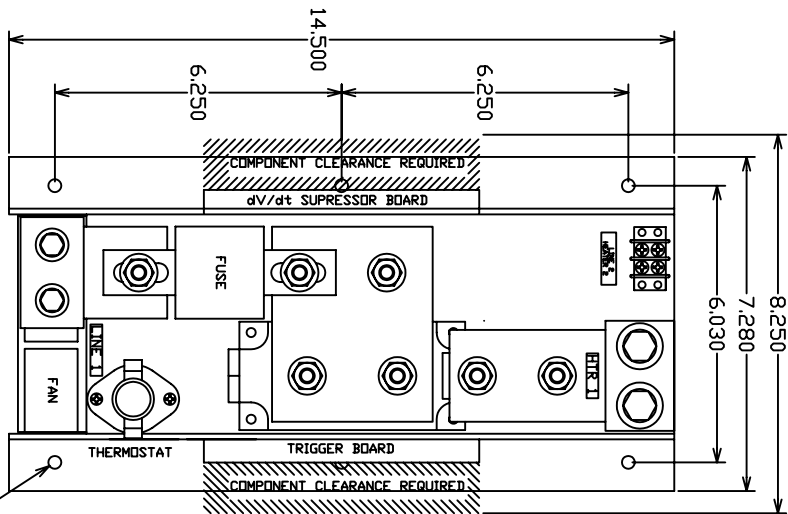
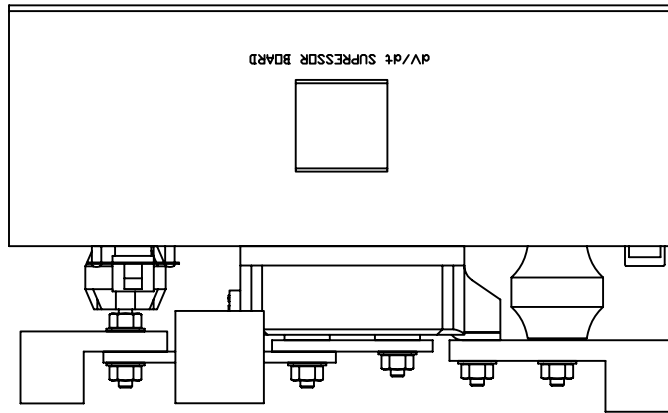

(6) MOUNTING HOLE DIAMETER 0.275"

PHYSICAL DIMENSIONS

B2P - 1200 AMP

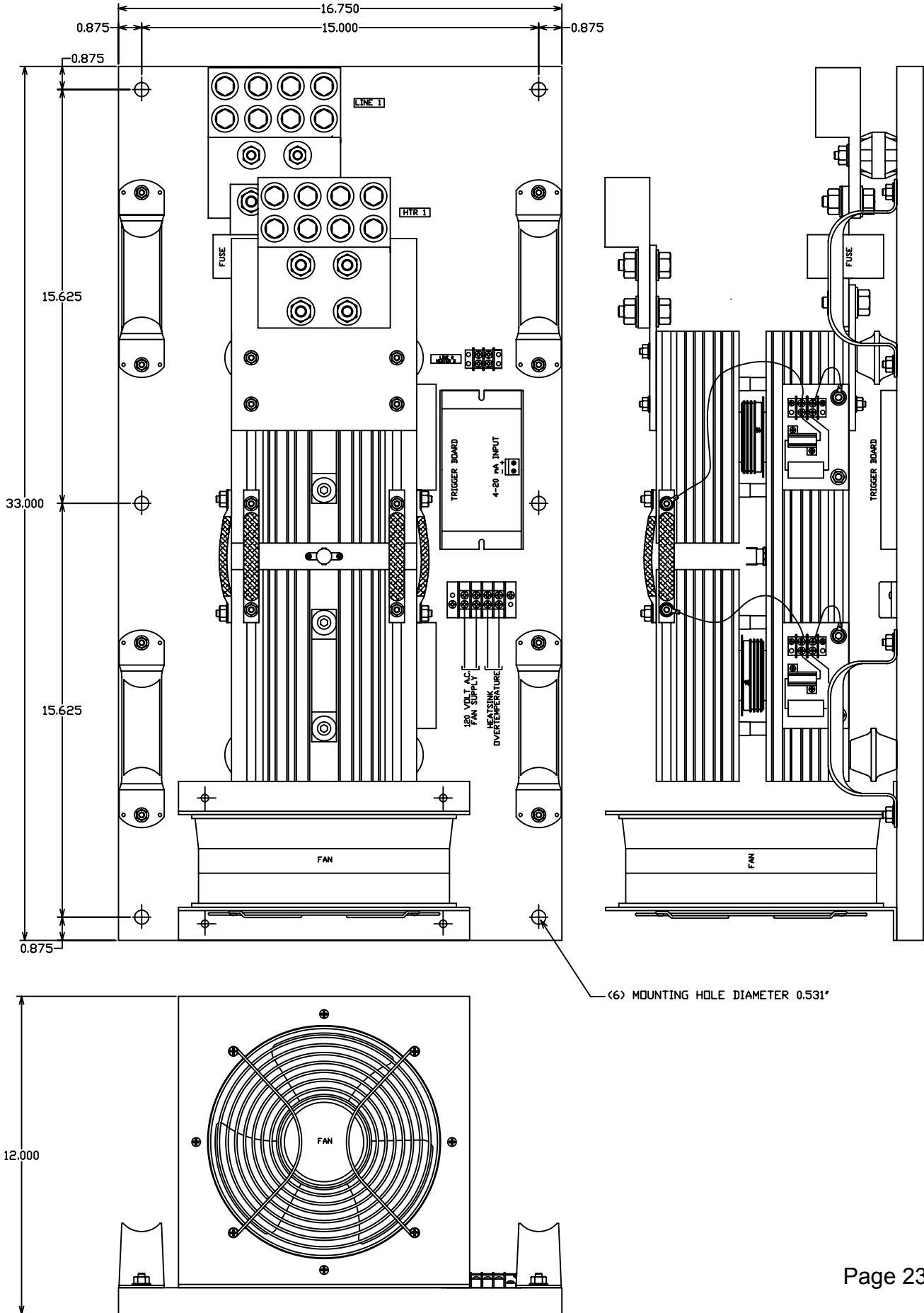



Avatar Instruments, Inc.
Phone: (610) 543-5155,

577 Abbott Drive
Fax: (610) 543-5255

Broomall, PA 19008
www.scrpower.com