



## A3P OPERATING MANUAL

### TABLE OF CONTENTS

Introduction.....	p. 2
Features .....	p. 2
Description.....	p. 3
Theory of Operation .....	p. 3
Installation .....	p. 4
Electrical Connections .....	p. 5
Options.....	p. 6
Warranty .....	p. 6
Specifications .....	p. 7
Troubleshooting .....	p. 8
Ordering Codes.....	p. 9
Wiring Diagrams .....	p. 10 - 15
Dimensional drawings .....	p. 16 - 24



84XK File # E207795

Avatar Instruments, Inc.  
Phone: (610) 543-5155

577 Abbott Drive  
Fax: (610) 543-5255

Broomall, PA 19008  
[www.scrpower.com](http://www.scrpower.com)

# INTRODUCTION

Congratulations on your purchase of an Avatar A3P series power control. This manual was designed to assist you in installing, operating and maintaining your new power control in a safe manner. Upon reading and following the instructions in this manual, you will be rewarded many years of trouble free service from your new A3P. If reading manuals is not for you, it is essential that you at least read the captions followed by the safety warnings; they are located through out the manual and are very easy to identify.



indicates important installation, operating, servicing instructions



indicates dangerous voltage present and risk of electric shock

# FEATURES

- UL 508 listed
- compact and light weight
- 100 % solid state circuitry
- over-rated SCR power modules
- over-sized heat sink
- full power ratings up to 50°C (122°F) ambient temperature
- optically isolated 4-20 mA input standard
- thermostats standard on fan-cooled units
- electrically isolated chassis and heat sinks
- gold alodined chassis and heat sink
- I<sup>2</sup>T fusing and MOV protection on all power SCR's
- SanRex, SemiKron, International Rectifier and Fairchild semiconductors
- double sided FR4 VO-94 rated glass epoxy PCB's

## DESCRIPTION

The A3P is a proportional, infinitely variable power controller capable of delivering 0-97% of the applied line voltage to directly connected electric heaters. It will not control transformers or motors. This is accomplished by phase angle firing three SCR's (one per phase). Modular construction allows for simple and solderless field serviceability. There are four field replaceable items:

- printed circuit board
- fuses
- SCR/ diode packages
- MOV's (metal oxide varistors)

## THEORY OF OPERATION

The standard input signal (4-20mA) is applied to the blue input terminal block, processed and series fed to three optical couplers. The output of each opto coupler controls the drive circuit for its associated phase which is then fed to its respective SCR. I<sup>2</sup>T fuses connected in series with each phase input provides over current protection in the event of external wiring shorts, and or too large of a heater load. Additionally, a MOV (metal oxide varistor) is connected in parallel with each SCR/ diode, providing voltage spike protection to the controller. Diodes are used in series with the SCR for sound engineering factors: Diodes are stronger than SCRs. Diodes can take higher temperatures than SCRs. Diodes will not misfire.

### PHASE ANGLE FIRED

These controls proportionally turn on a percentage of each power line half cycle. This gives smooth, infinitely variable application of power to the heaters. Imagine a light dimmer and how it provides power to a light bulb. This method will provide the most precise control of heaters. Phase angle fired SCR's will respond the fastest to load change and provide maximum heater life. It is the most precise method of control. Phase angle firing can increase heater *life up to seven times depending on heater type*. Phase angle firing also allows options such as soft start, voltage limit and current limit. These options are not available with any other means of control. Graphs below shows **phase angle fired** voltage output on a 240V power line.

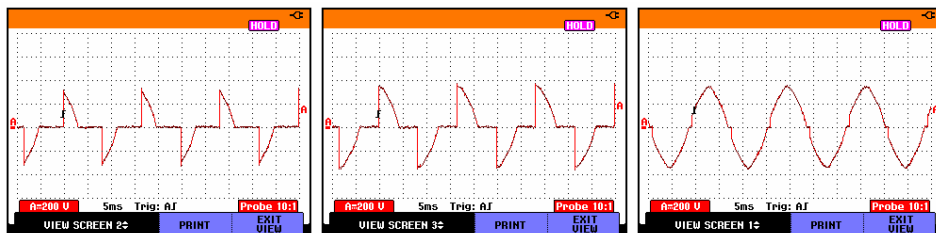

25% output or 60V RMS

50% output or 120V RMS

99.5% output or 238.8V RMS

## INSTALLATION



**WARNING: FIRE HAZARD!!** Even the best electronic components CAN FAIL SHORTED, KEEPING FULL POWER ON! Provide a completely SEPARATE (redundant) OVER TEMPERATURE SHUTDOWN MEANS to switch power off if safe temperature is exceeded.



**WARNING: HIGH VOLTAGE!!** This control must be installed in a GROUNDED enclosure. Provide a safety interlock on door to remove power before gaining access to device.



This controller must be installed by a qualified electrician in accordance with any and all local and national electric codes including NEC and any other applicable codes.

First things first, do you have the proper controller for your application? Check the Avatar serial tag and verify the correct voltage/ ampere ratings and input control signal for your application.

After verifying you have the proper controller, the next most important item is adequate cooling/ ventilation. All Avatar power controllers are rated to deliver full power to their respective load(s) at an ambient temperature not to exceed 50 degrees C. Use this formula to calculate the minimum size enclosure required.

**3 X 1.2 VOLTS X MAXIMUM HEATER CURRENT = TOTAL WATTS DISSIPATED**

**example: 3 x 1.2 x 60 amps = 216 watts that the power controller has to dissipate**

Heat is the worst enemy to any electrical device, including power controllers. Orient heat sink fins and chassis channel in a vertical position, providing adequate air flow above and below unit. The cooler the unit operates, the longer it will provide seamless, reliable service.

The dryer and cleaner, the better! Over time, a combination of moisture and contaminants will lead to failure due to corrosion and insulation breakdown (arcing and sparking). If the controller absolutely must be installed in a harsh and corrosive environment, it is recommended that an air conditioned NEMA 4X or similar type of environmentally sealing enclosure be used during installation.

# ELECTRICAL CONNECTIONS



Again, this work must be performed by a qualified electrician and in accordance with any and all local and national codes that may apply. Please refer to the wiring diagrams (pgs. 10 - 15).



To reduce the risk of electrocution, **TURN ALL POWER OFF** to wires that will be connected to the power control before making any connections. The standard A3P controller must be installed in a metal enclosure for protection against electrocution.

## **AC POWER INPUT:**

Power input (AC MAINS) is connected to lugs labeled "LINE 1", "LINE 2", and "LINE 3" (see fig. 1 for correct wire size and torque specs.), phase rotation or orientation (i.e. ABC or ACB, etc.) is not critical.

## **LOAD CONNECTION:**

Load connections are equally simple; connect the load/ heater to lugs labeled "HTR 1", "HTR 2", and "HTR 3" (see fig. 1 for correct wire size and torque specs). A3P's will accept delta or wye configured loads.

**NOTE: "wye" connected loads MUST NOT USE the "neutral" or 4th wire from the voltage source! Open Delta wiring will result in 50%-100% output only and should be controlled by a 3CP or (3) A1P controls instead.**

The A3P is capable of driving unbalanced loads, but it is highly recommended to equally **BALANCE LOADS BETWEEN ALL THREE PHASES** to provide consistent tracking between all three phases.

Check heater resistance to insure heater current will not exceed fuse ratings. Controllers DO NOT blow fuses - excess heater current does. Check for heater wiring shorts, shorted load connections will instantly blow expensive fuses.

## **INPUT CONTROL SIGNAL:**

Connect the control signal to the blue terminal block labeled "4-20mA INPUT" observing proper polarity (positive to "+" and negative to "-").

## **THERMOSTAT for FAN FAILURE:**

On all Avatar SCR Controls 150 Amps and above, fans are used to cool the SCR heat sinks. Avatar mounts a Snap-disc thermostat to the heat sink. If the fan fails, air is blocked or a safe ambient temperature is exceeded, the thermostat will activate. This thermostat can be used to break 4-20mA input signal, trigger alarms or shut down a power contactor. See wiring diagrams for thermostat wiring (pgs. 12 and 13).

## OPTIONS

**SOFT START:** The soft start is made for applications where heaters have inrush currents. For use with Tungsten (T-3), Molybdenum or Graphite heaters, order with Soft Start Option. This option is designed to ramp power from 0-100% over a fixed time period. This time is 2 (S02) 5 (S05), 10 (S10) or 20 (S20) seconds depending on option ordered. If the input signal goes to 4mA (0%), the soft start will engage for the full length of time when the mA signal is reactivated. The soft start option will also restart if line voltage is interrupted to the SCR. Extra DV/DT Suppression board and Voltage Limit included with option.

**VOLTAGE LIMIT:** The voltage limit option (VL) is used to reduce the maximum output voltage applied to the heaters. The adjustment is located on the trigger board close to the 4-20mA input signal terminal. It is marked as "V-LIM". To set the voltage limit, connect a volt meter across HEATER 1 & HEATER 2. **THERE MUST BE A LOAD CONNECTED FOR SCR TO FIRE.** With a full 20mA input signal, turn potentiometer CCW to reduce maximum output voltage to desired level. This option comes as standard on soft start option.

**CURRENT LIMIT:** The CL & CLP option is designed to monitor and limit the output current of the SCR. Avatar Instruments provides the current transformer(s) (CT) and hard wires them to the trigger board. Simply put the LINE 1 input wire through the current transformer located next to the LINE 1 set screw lug. On A3P controllers, put the LINE 1, LINE 2 & LINE 3 input wires through the CT's (as marked).

**Adjusting current limit:** To set the current limit, connect an Amp-probe onto the HEATER 1 output wire. **THERE MUST BE A LOAD CONNECTED FOR SCR TO FIRE.** On SCR's with "-CL" option, the potentiometer adjustment is located on the PCB. With a full 20mA input signal, turn potentiometer counter clockwise (CCW) to reduce maximum output voltage to desired level. The "-CLP" option has a panel-mount potentiometer (3/8"), knob & scale. Turn the potentiometer counter clockwise (CCW) or lower on the 0-100 scale, to reduce maximum power output.

For manual control use Avatar model **MAP**. Isolated Potentiometer 4-20mA signal card.

For LINEAR 0-5 or 0-10 VDC Analog Signal use Avatar MAI milliamp interface card.

**MAI-05V** takes a 0-5VDC signal input and outputs 4-20mA.

**MAI-10V** takes a 0-10VDC signal input and outputs 4-20mA.

## WARRANTY

All Avatar Instruments products carry a full five year, warranty from date of purchase, parts and labor warranty against component failure and defects in workmanship. In the event your controller fails to perform properly, **contact Avatar to obtain a return authorization number.** Controllers sent to Avatar for warranty service that have no apparent defect will be treated as a standard repair and a \$50.00 charge will be applied. Avatar will repair or replace any unit that failed due to defective parts or assembly. This warranty **DOES NOT** cover damage due to shipping, abuse, misapplication or operation beyond specified rating. Furthermore, fuses and improperly fused SCR's are **NOT COVERED** by this warranty. Avatar is not responsible for any subsequent or other damage experienced in use of this device.



## TROUBLESHOOTING

SYMPTOM	POSSIBLE CAUSE	POSSIBLE SOLUTION
Heater does not heat up	no power to A3P	verify correct input voltage between "LINE" lugs on A3P.
	blown fuse in A3P	check for shorted or grounded heater, oversize heater, only then replace fuse. For tungsten Lamps order soft start option.
	blown fuse on A3P-S-	as above plus - cold lamp switched on after start, loose connection to cold lamp.
	check voltage limit adjustment on A3P with soft start (A3P-S-)	If limit is set for minimum output (CCW), soft start could take over 60 seconds worst case.
	no control signal to A3P	verify 4-20mA signal is hooked up correctly (positive to "+" and negative to "-") on the source and A3P. verify signal presence by placing a milliamp meter in SERIES with one of the control wires.
	defective heater	check for output voltage between the three "HTR" terminals. If voltage is present, check wiring to the heaters and the actual heaters.
Heater is on full all the time	incorrect source signal	verify 4-20mA signal varies from 4-20mA.
	shorted SCR's in A3P	with power applied, measure voltage drop across "LINE 1" and "HTR 1", if voltage reading is less than one volt, the SCR's are damaged, using the same method, check LINE 2-HTR 2 and LINE 3 - HTR 3.
Heater is on 25-50% all the time	Short to ground	Heater or power wiring has a short to ground, effectively bypassing SCR. Use Meg-Ohm to find short or breakdown in wire insulation.
Process will not stabilize - control signal oscillates	incorrect tuning of temperature controller, bad sensor location or lag	set proper rate, reset, and prop band on temperature control, speed up sensor.

## A3P SERIES SCR POWER CONTROLLERS

### ORDERING CODES

A3P -            -            -            -             
          Voltage    Amperes    Options    Options

### VOLTAGE DESIGNATIONS

(12) 120 VAC 50/60Hz  
(24) 208-240 VAC 50/60Hz  
(27) 277 VAC 50/60Hz  
(38) 380 VAC 50/60Hz  
(48) 480 VAC 50/60Hz  
(57) 575 VAC 50/60Hz  
(60) 600 VAC 50/60Hz

### LOAD IN AMPS:

30, 40, 60, 80, 100, 150  
200, 225, 250, 350, 500

### OPTIONS:

#### Soft Start

2 Seconds (S02)  
5 Seconds (S05)  
10 Seconds (S10)  
20 Seconds (S20)

Note: Soft start gets voltage limit option.

#### Current Limit (CL)

(CLP) with panel mount potentiometer)

#### Voltage Limit

Standard 1 turn PCB (VL)  
25 turn PCB (VL25)

**Example:** A3P-24-60-S05 is a 240VAC, 60 Ampere SCR with 5 second soft start

# A3P WIRING DIAGRAM (3 WIRE 3 LEG DELTA LOAD)

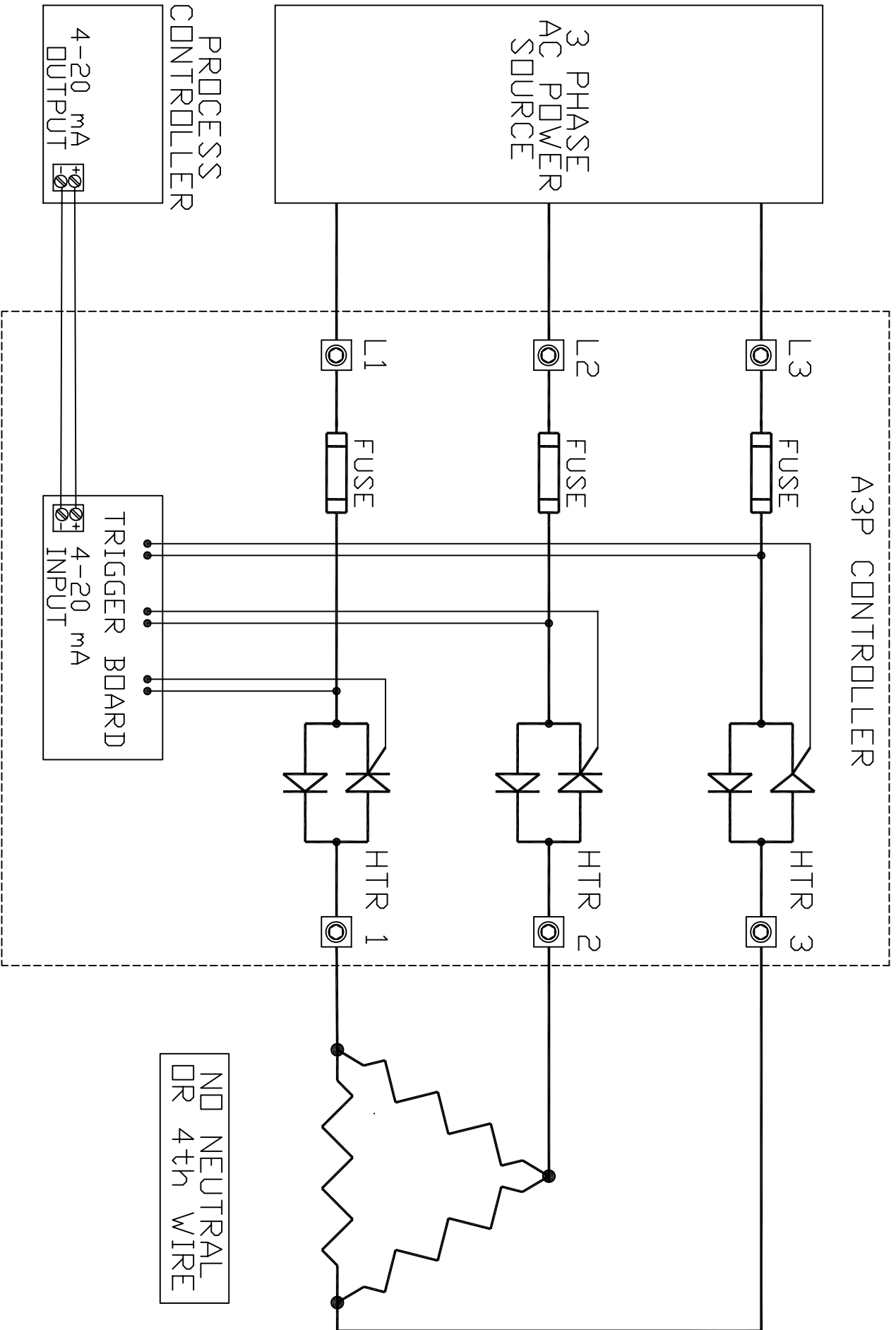

# A3P WIRING DIAGRAM (3 WIRE 3 LEG WYE LOAD)

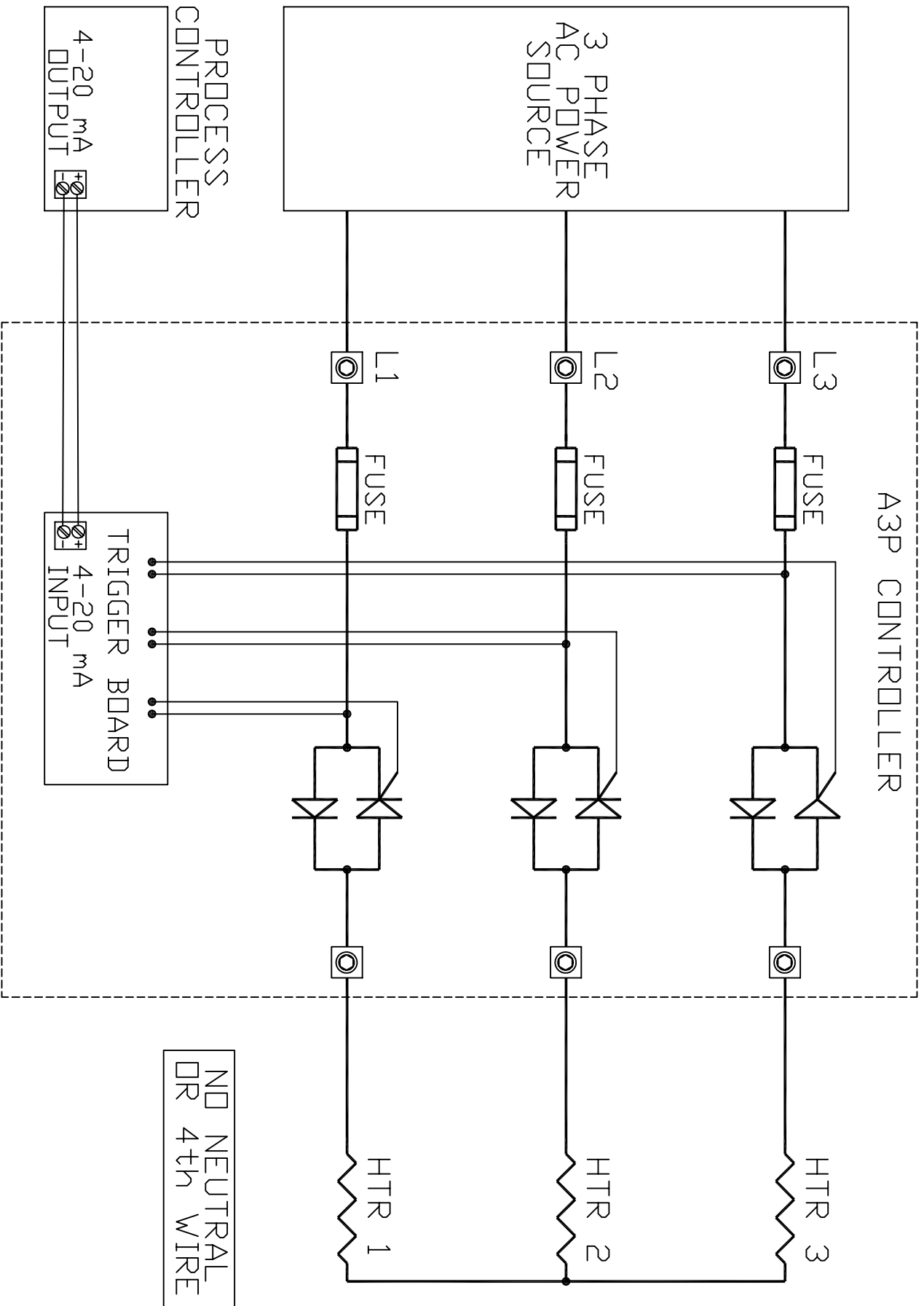

# OVERTEMPERATURE THERMOSTAT WIRING DIAGRAMS

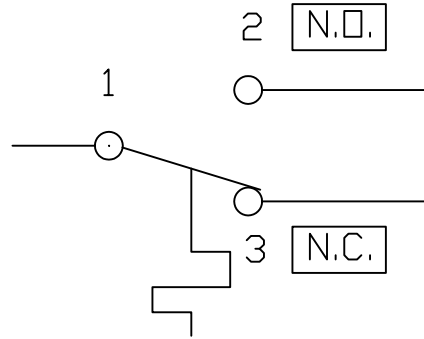
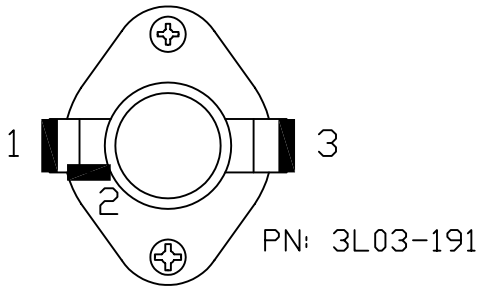

## CONTACT RATINGS

1 & 2:  
5.8A 120VAC  
2.9A/240VAC

1 & 3:  
10A/120VAC  
5A/240VAC

OPEN: 190F  
CLOSE: 170F

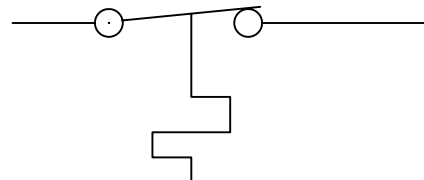
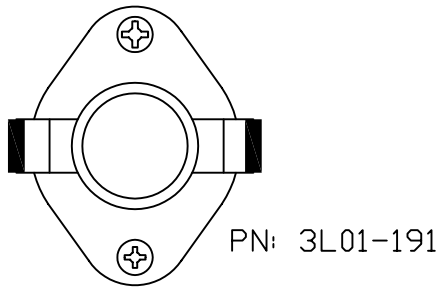

CONTACT RATING:  
10A/120VAC  
5A/240VAC

OPEN: 190F  
CLOSE: 170F

# FAN WIRING DIAGRAMS

## 100 thru 600 AMPS

TERMINAL TYPE 6.9

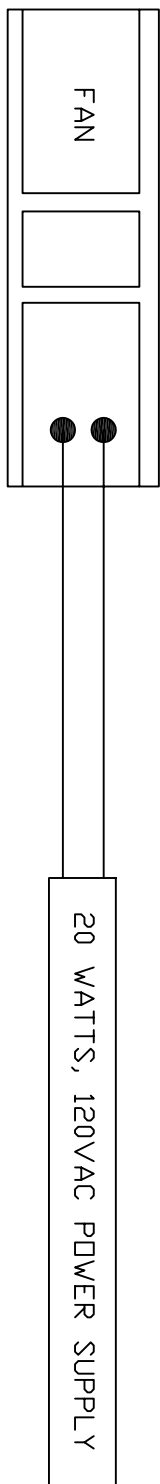

**WARNING!**  
Fans MUST be ON when SCR power controller is on!  
Power to fans must be applied before or coinciding with the turn on of line voltage to the SCR power controller. *Failure to do so will damage SCRs and other components.*

TERMINAL BLOCK

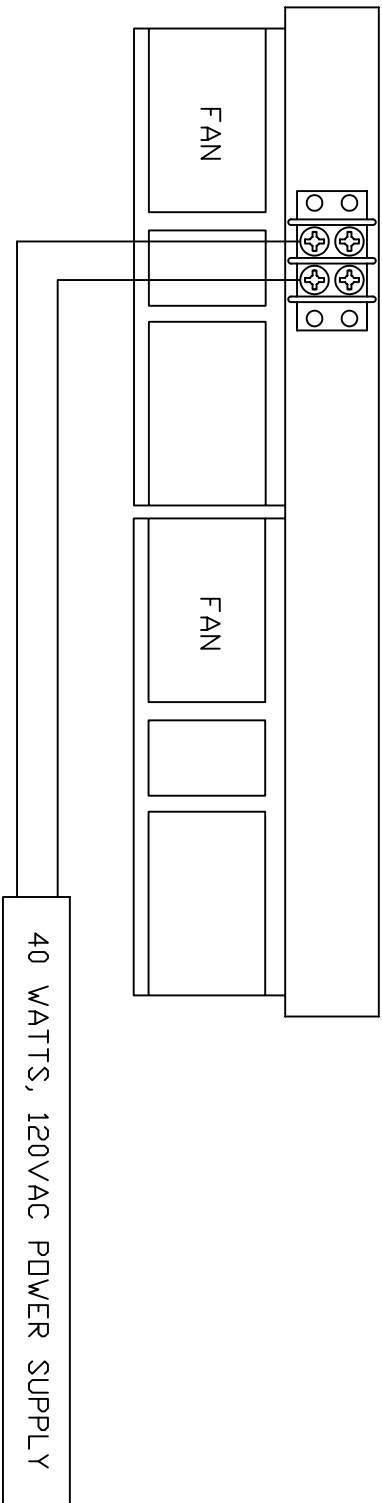

TERMINAL BLOCK

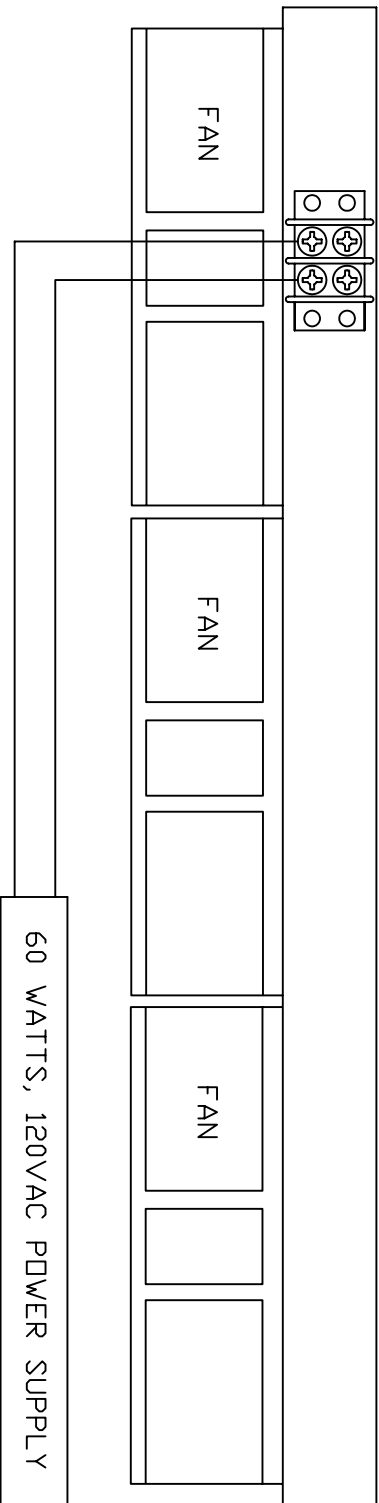

# CURRENT LIMIT CARD WIRING DIAGRAMS

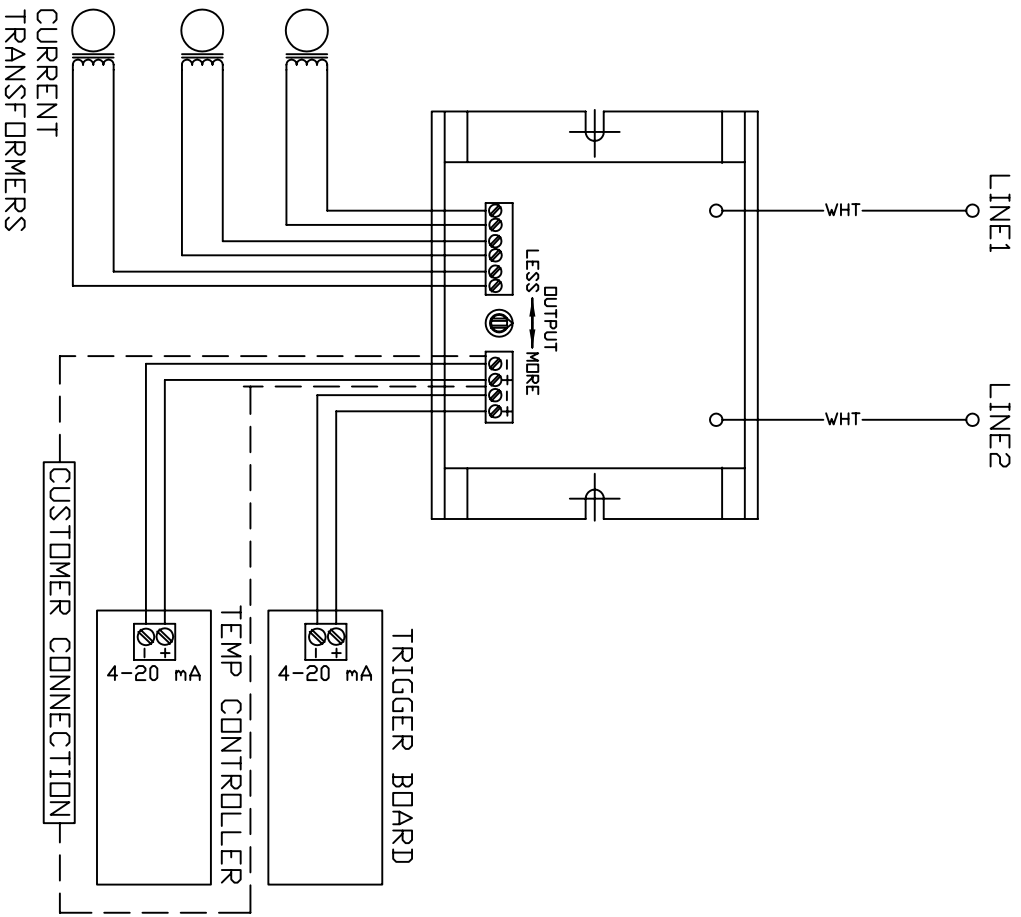

**3 PHASE**

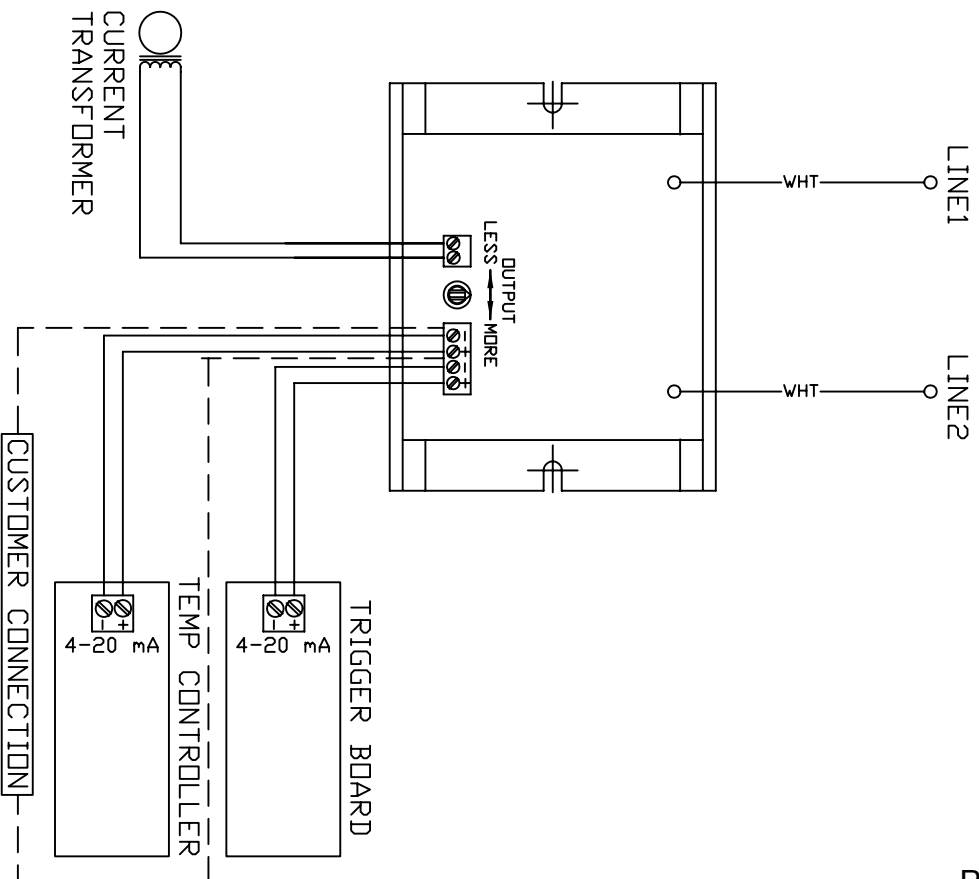

**SINGLE PHASE**

# CURRENT TRANSFORMER INSTALLATION DETAIL

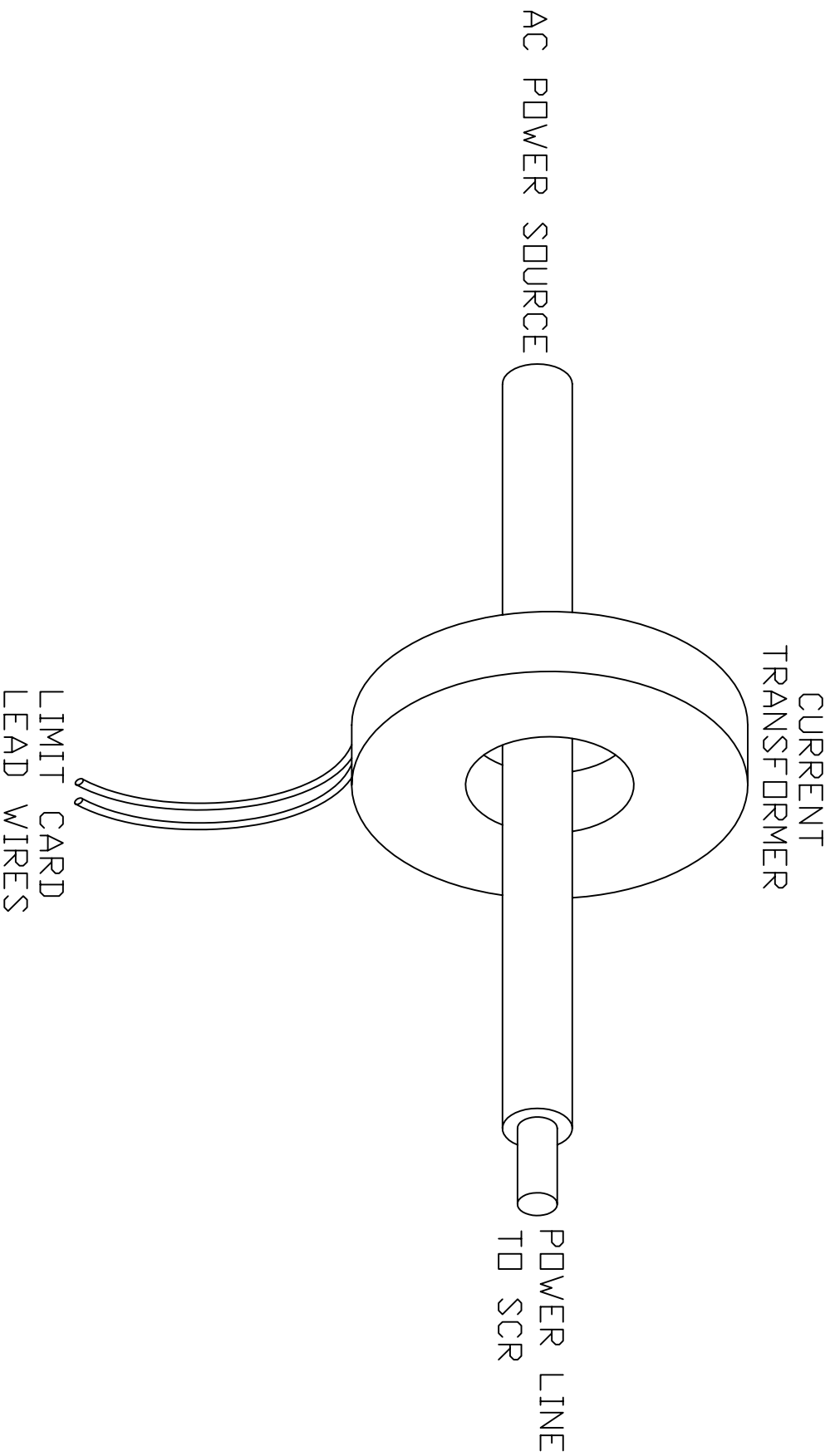

# PHYSICAL DIMENSIONS CURRENT TRANSFORMERS

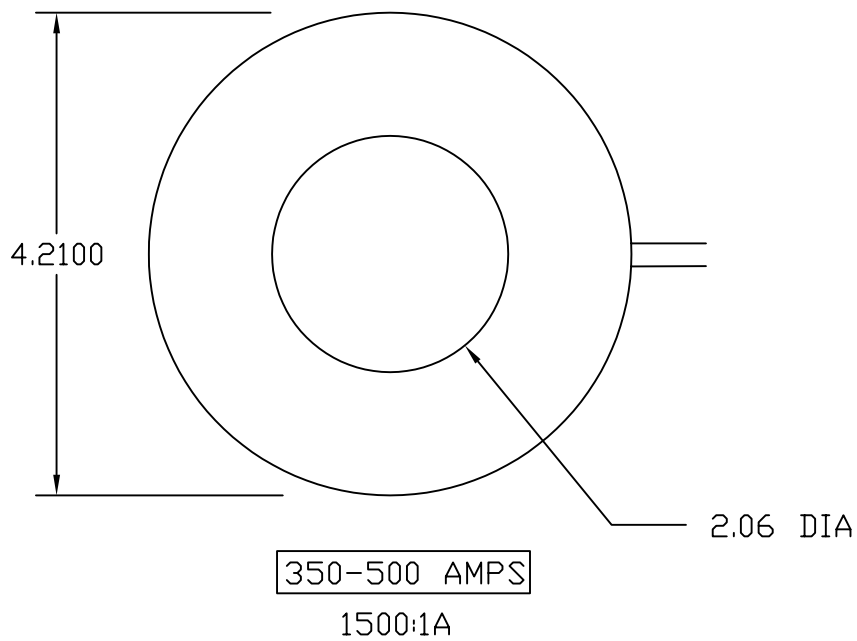
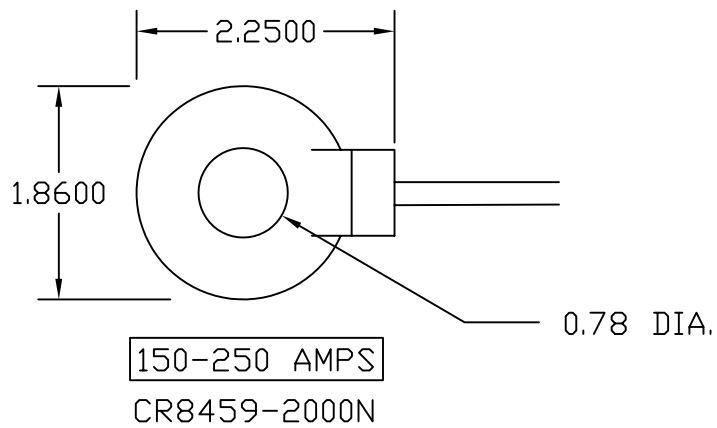
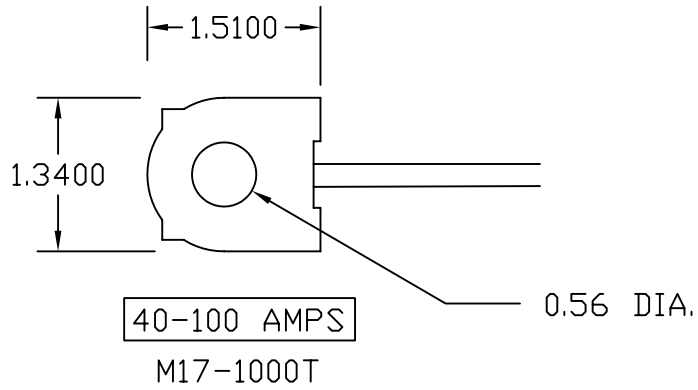
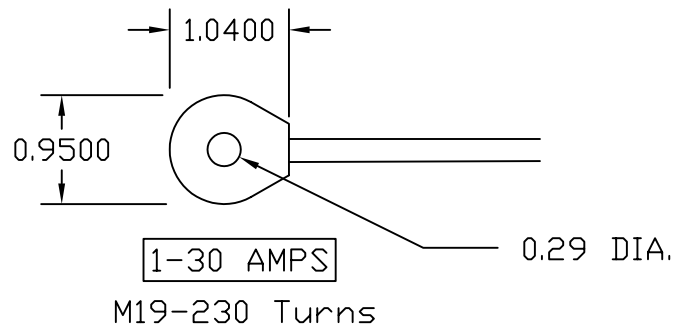

# PHYSICAL DIMENSIONS

## A3P - 30 AMP

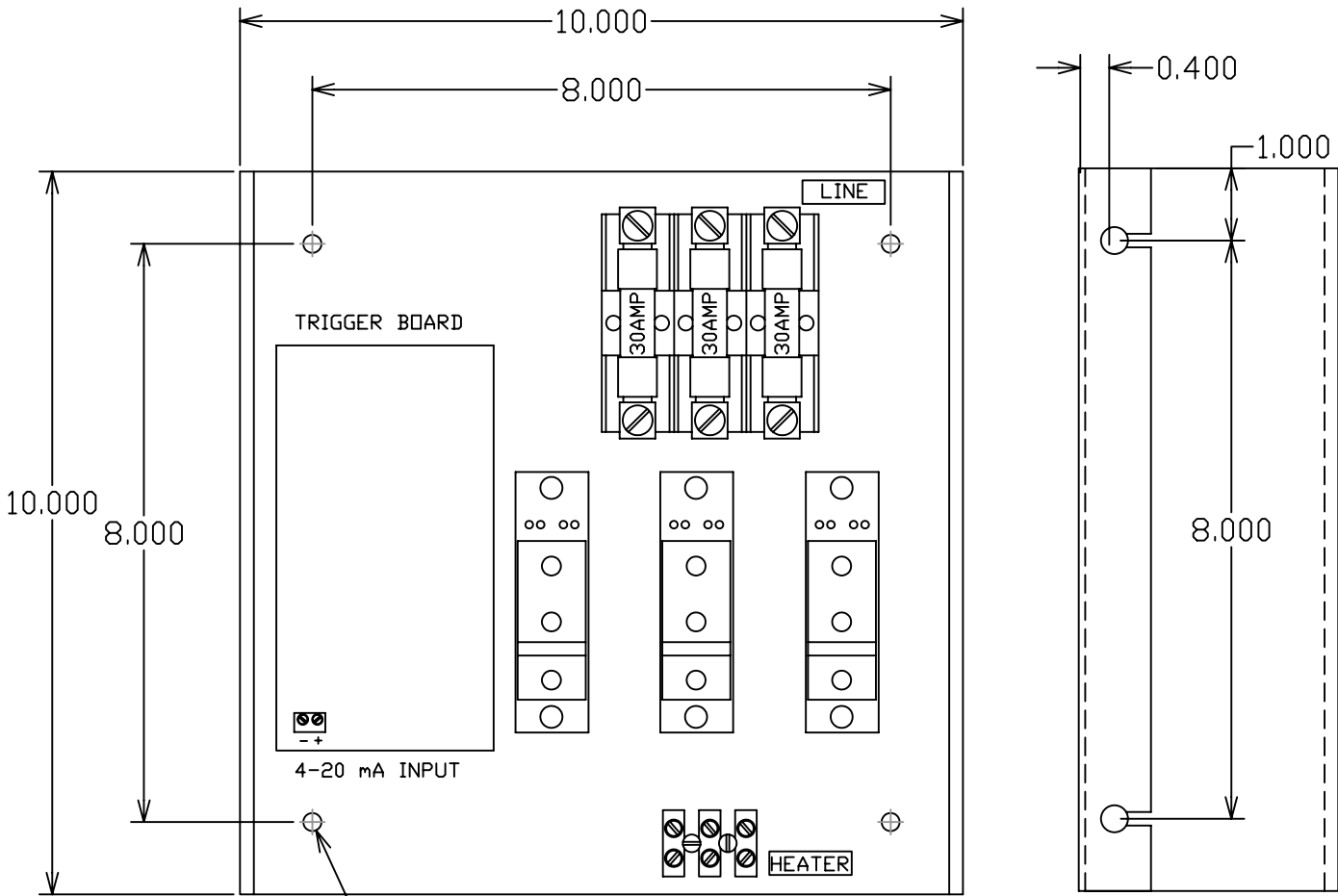

(4) MOUNTING HOLE DIAMETER 0.275"

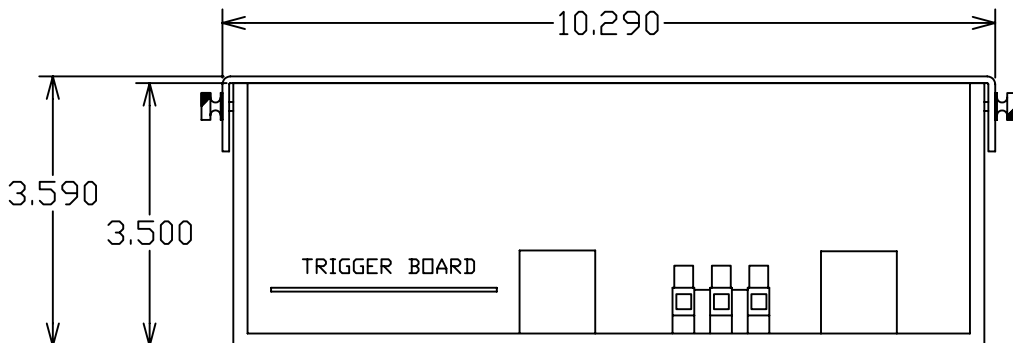

# PHYSICAL DIMENSIONS

## A3P - 40, 60 & 80 AMP

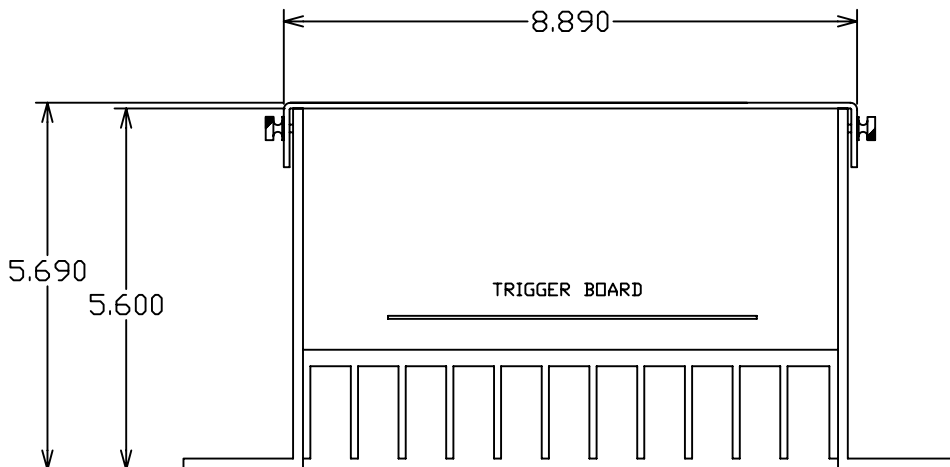
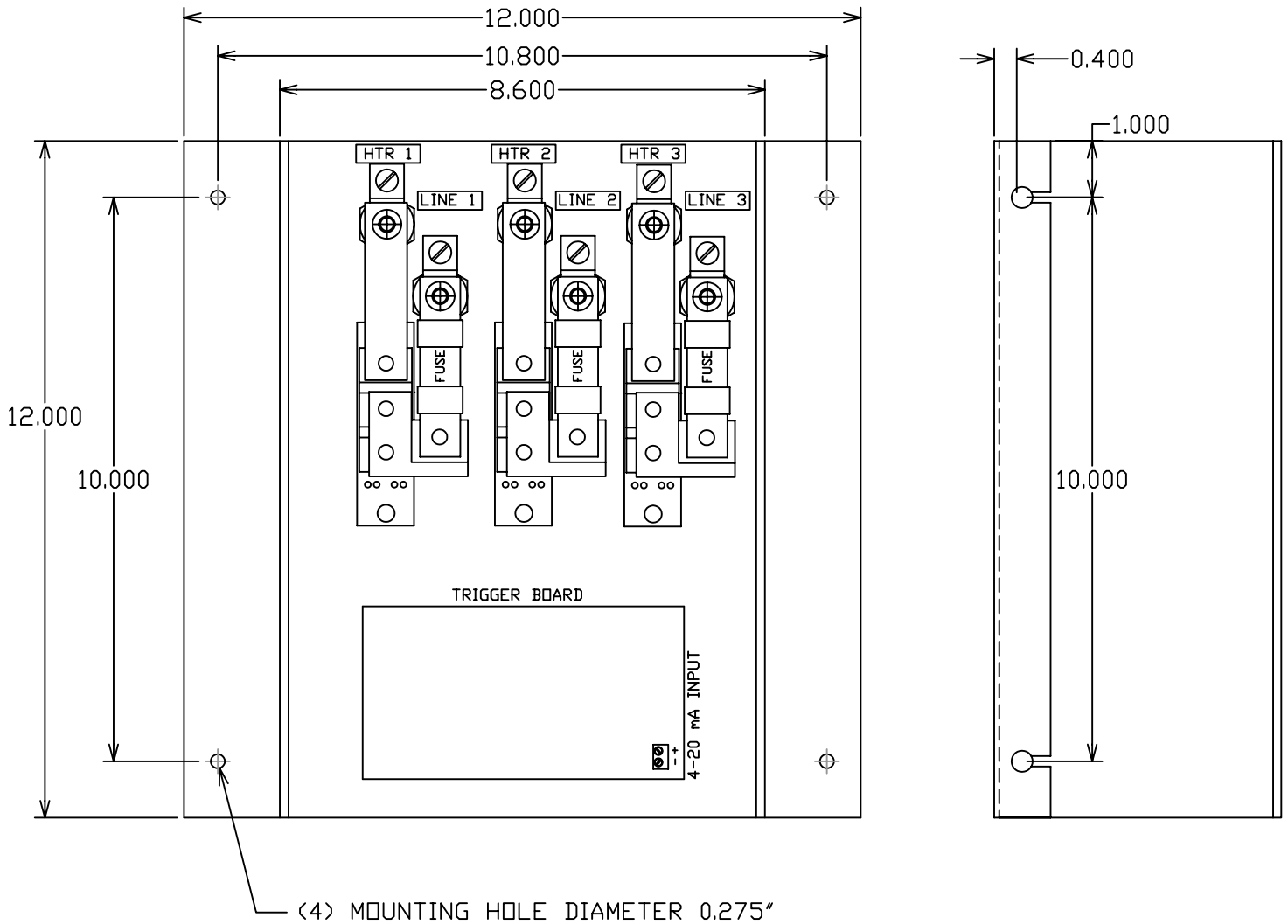

# PHYSICAL DIMENSIONS

## A3P - 100 AMP

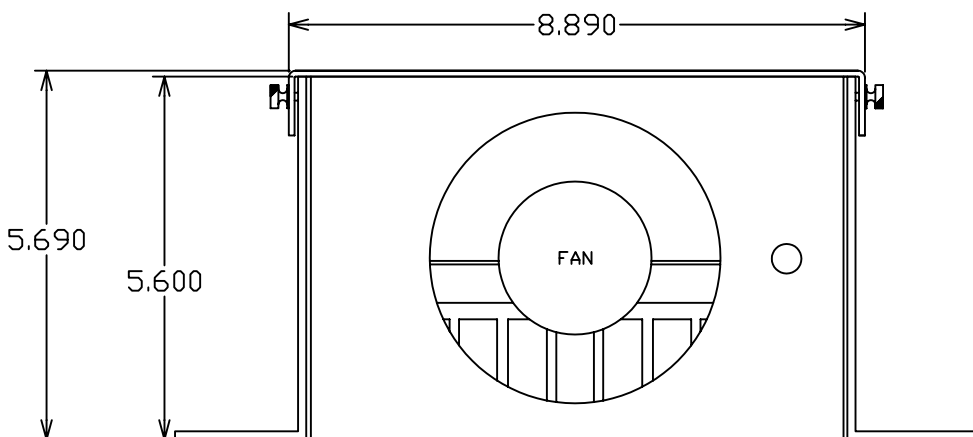
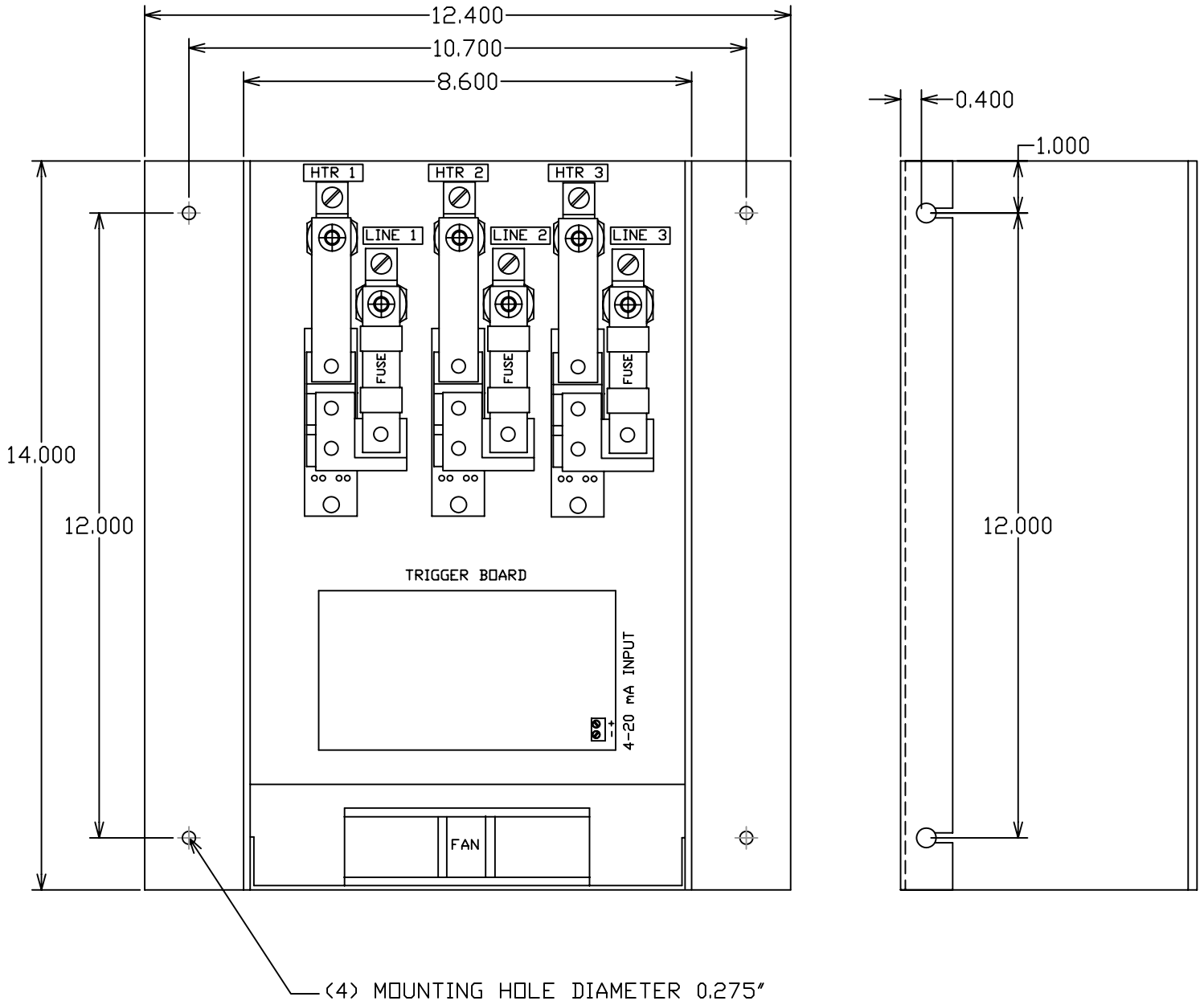

**PHYSICAL DIMENSIONS**  
**A3P - 40, 60, 80 & 100 AMP**  
**THROUGH-HOLE MOUNTING (-TH)**

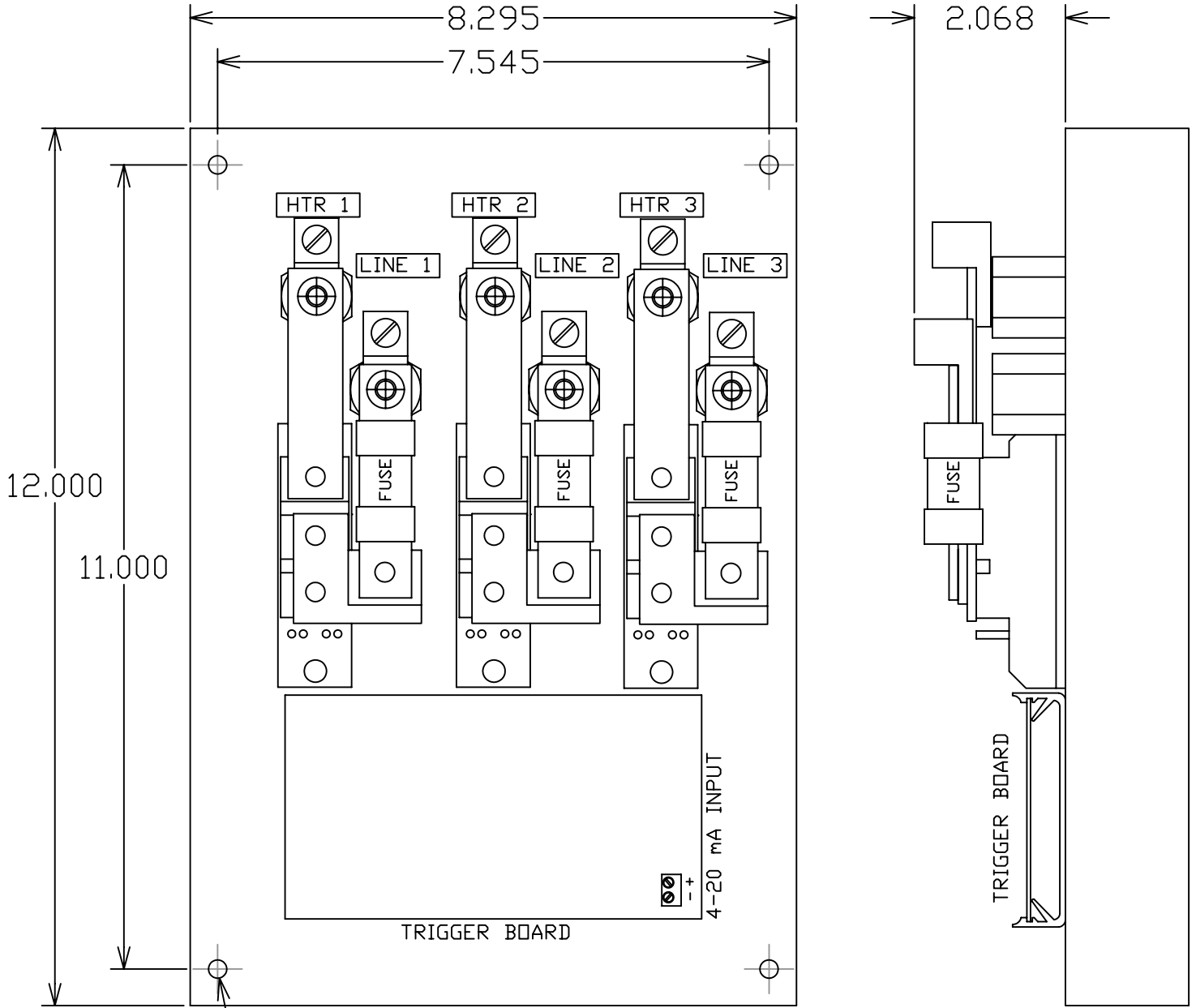

(4) 1/4"x20 TAPPED MOUNTING HOLE

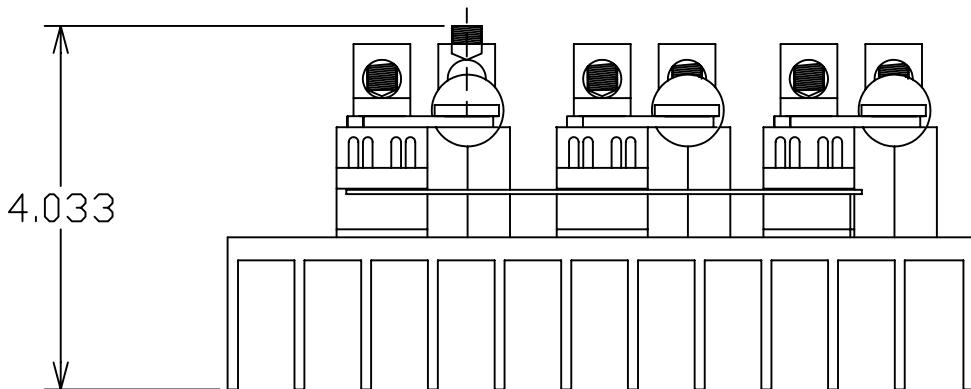

# PHYSICAL DIMENSIONS

## A3P - 150 AMP - COMPACT (-C)

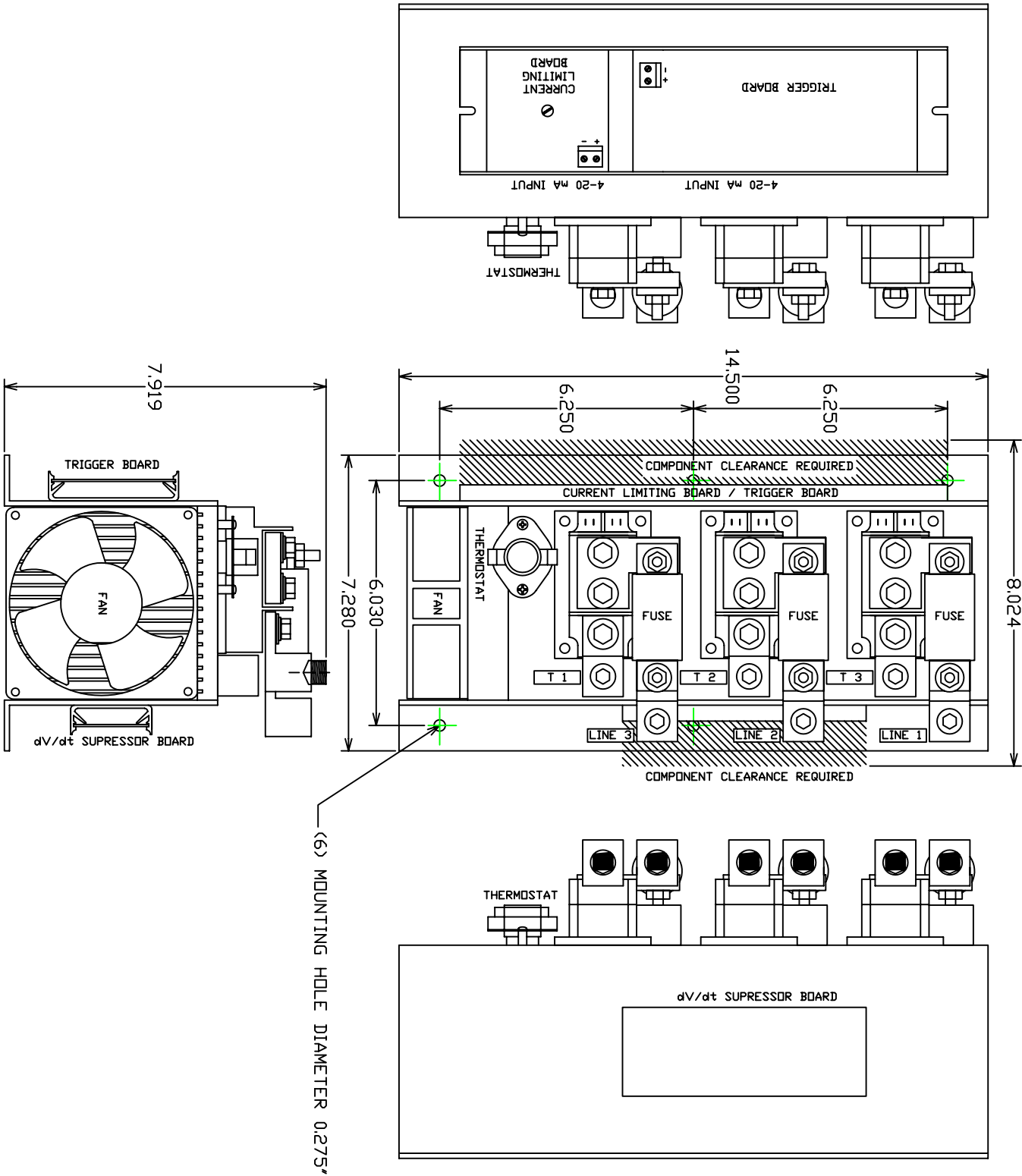

# PHYSICAL DIMENSIONS

## A3P - 150, 200, 225 & 250 AMP

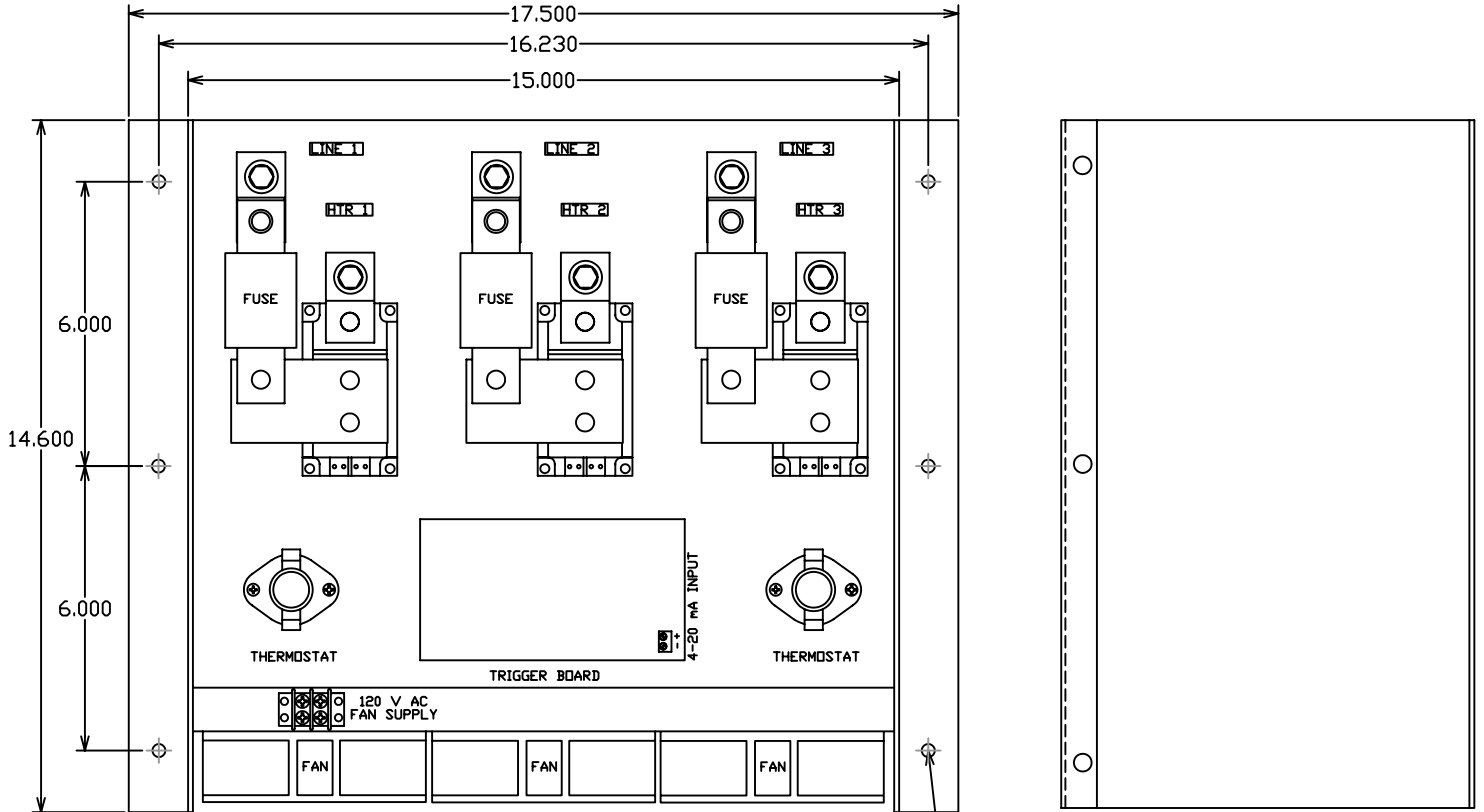

(6) MOUNTING HOLE DIAMETER 0.275"

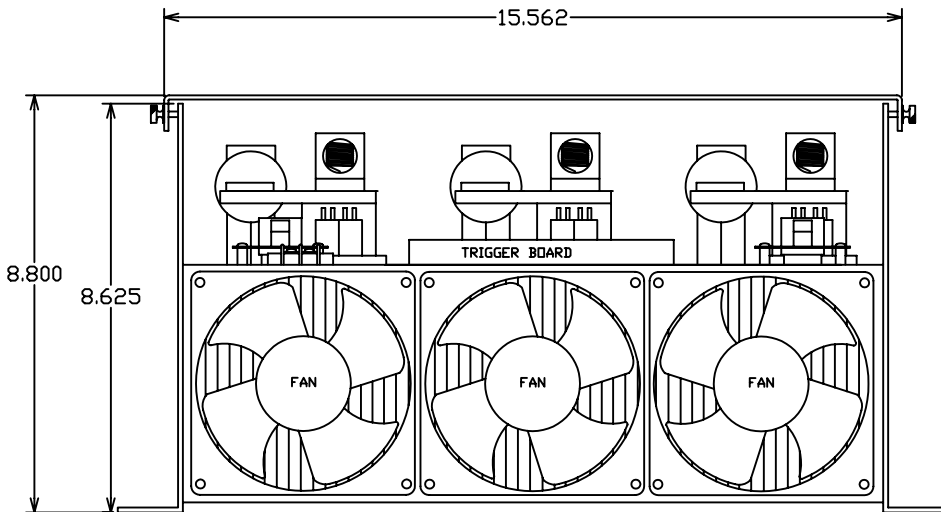

# PHYSICAL DIMENSIONS

## A3P - 350 AMP

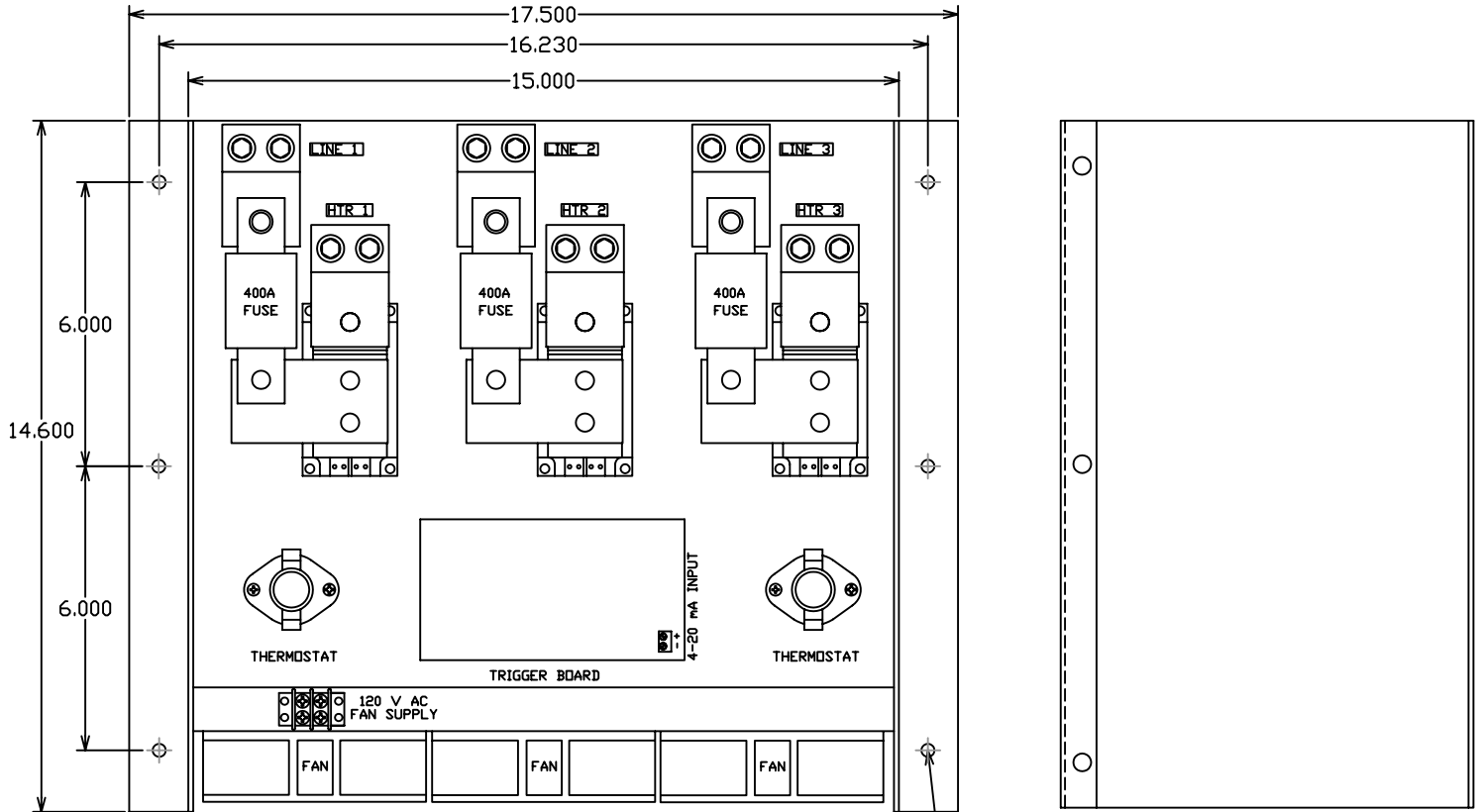

(6) MOUNTING HOLE DIAMETER 0.275"

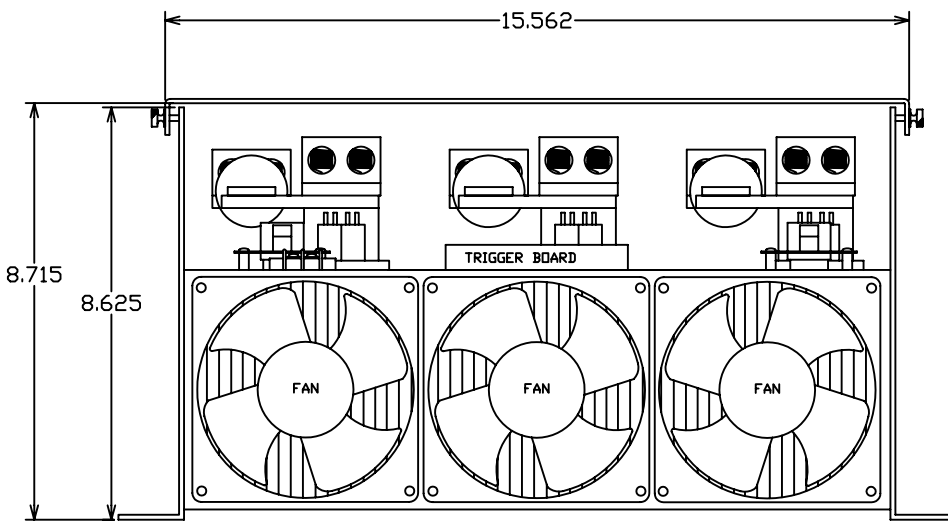

# PHYSICAL DIMENSIONS

## A3P - 500 AMP

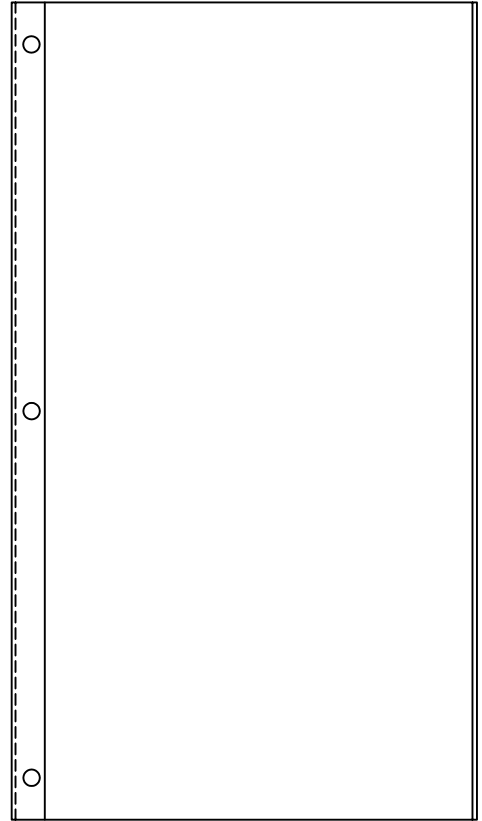
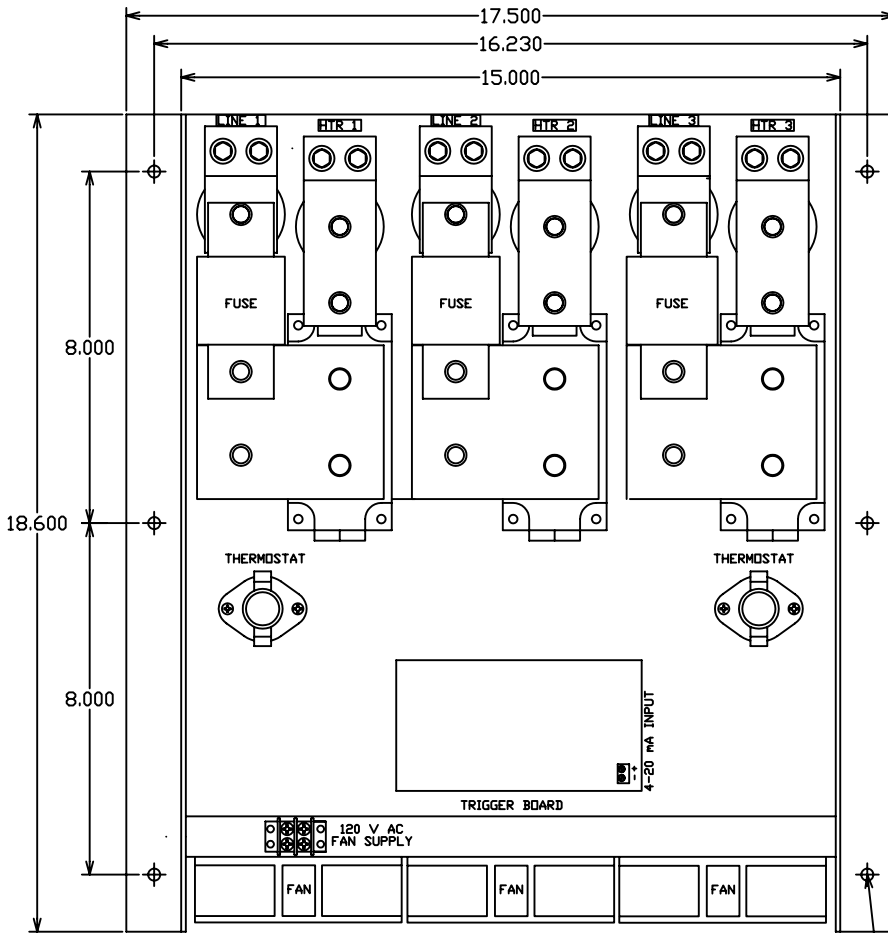

(6) MOUNTING HOLE DIAMETER 0.275"

