

AVATAR INSTRUMENTS 'R' OPERATING MANUAL

CONFIGURATIONS

The R series controllers are available in three configurations.

R1 - single phase control

R2 - three phase two legs controlled, comprised of (1) R1 and (1) R slave.

R3 - three phase three legs controlled, comprised of (1) R1 and (2) R slaves.

See drawings for detailed configurations and wire connections.

DESCRIPTION The R1 is a proportional, zero voltage switched power controller capable of delivering 1-98% of the applied line voltage to the directly connected electric heaters. This is accomplished by varying the percentage of AC voltage cycles conducted by an SSR. The R series will not control transformers or motors.

OPERATION The R1 IS a solid state relay that takes a 4-32VDC input signal from a front-end controller and switches the heater load on/off. The R1 is a POWER CONTROLLER, it CANNOT create more voltage or current. There is no "tuning" or "tuning adjustments". *TROUBLESHOOTING TIP: phase angle fired controllers are recommended for very fast processes and low mass heaters.* Overall process control results are set by the dynamic characteristics of the heaters, transfer medium, sensor, and the tuning of the front-end controller, not the power controller.

INSTALLATION

WARNING: FIRE HAZARD!! Even the best electronic components CAN FAIL SHORTED, KEEPING FULL POWER ON! Provide a completely SEPARATE (redundant) OVER TEMPERATURE SHUTDOWN MEANS to switch power off if safe temperature is exceeded.

WARNING: HIGH VOLTAGE!! This control must be installed in a GROUNDED enclosure by a qualified electrician. Provide a safety interlock on door to remove power before gaining access to device.

ELECTRICAL CONNECTIONS See "WIRING DIAGRAM" on back. Check the Avatar serial tag and verify the correct voltage/ ampere ratings and input control signal for your application. Wiring must be performed in accordance with any and all applicable local and national codes. Use a minimum wire size of 16AWG for a 10 amp R, 14AWG for a 15 amp R, and a minimum of 10AWG for a 25 amp R. For best results keep control signal and power wires separated.

OPTIONS

120VAC INPUT SIGNAL: add "-120" to part number.

MANUAL CONTROL: Use Avatar MTP Isolated Potentiometer.

THROUGH-HOLE MOUNTING: add "-TH" to part number **R2 ONLY.**

UNIT MOUNTED FUSE: add "-F" to part number. **See R1, page 3 for fused unit.**

WARRANTY All Avatar Instruments products carry a full three year, from date of purchase, parts and labor warranty against component failure and defects in workmanship. In the event your controller fails to perform properly, **contact Avatar to obtain a return authorization number.** Controllers sent to Avatar for warranty service that have no apparent defect will be treated as a standard repair and a \$50.00 charge will be applied. Avatar will repair or replace any unit that failed due to defective parts or assembly. This warranty DOES NOT cover damage due to shipping, abuse, misapplication or operation beyond specified rating. Further more fuses and improperly fused SCR's are NOT COVERED by this warranty. Avatar is not responsible for any subsequent or other damage experienced in use of this device.



Avatar Instruments, Inc.
Phone: (610) 543-5155

577 Abbott Drive
Fax: (610) 543-5255

Broomall, PA 19008
www.scrpower.com

SPECIFICATIONS

INPUT SIGNAL:	4-32 VDC
OPTIONAL INPUT:	120 VAC contact closure
SUPPLY VOLTAGE:	120-600 VAC, 50/60 Hz
POWER CONSUMPTION (R1/R SLAVE)	
R1-48-10	15W per leg
R1-48-15	22.5W per leg
R1-48-25	37.5W per leg
CURRENT RATING (R1/R SLAVE)	
R1-48-10	10 amps
R1-48-15	15 amps
R1-48-25	25 amps
OPERATING TEMPERATURE (ambient):	50°C (10-25 amps)
RESPONSE TIME:	< 10mS
CONTROL METHOD:	zero voltage switched, Proportional
OUTPUT VOLTAGE:	1-98% of supply voltage

PHYSICAL DIMENSIONS and WIRING DIAGRAM

R1 - 15 & 25 AMP

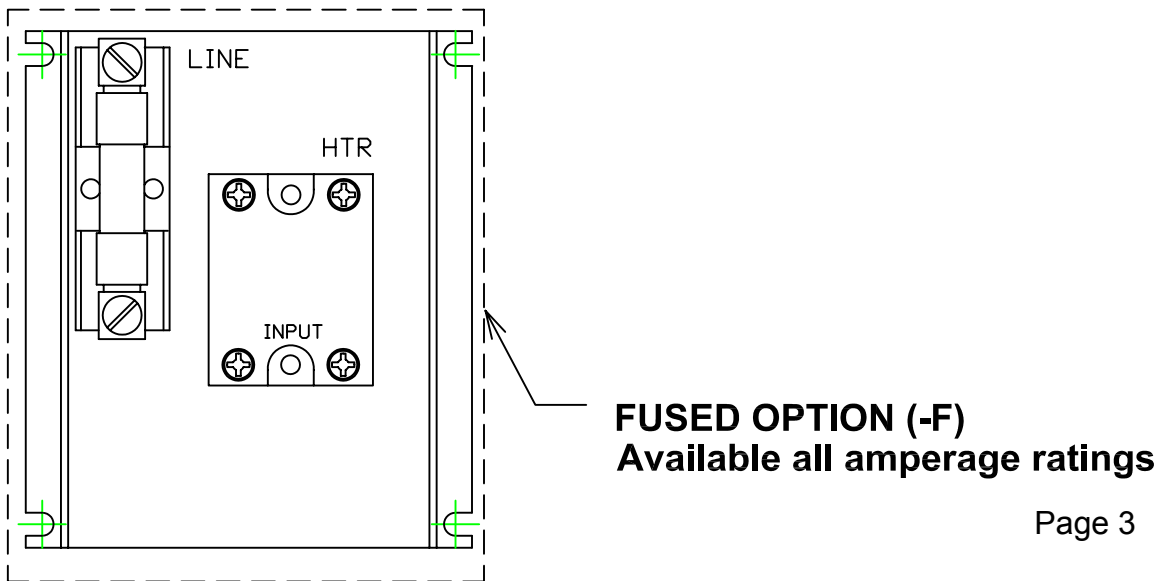
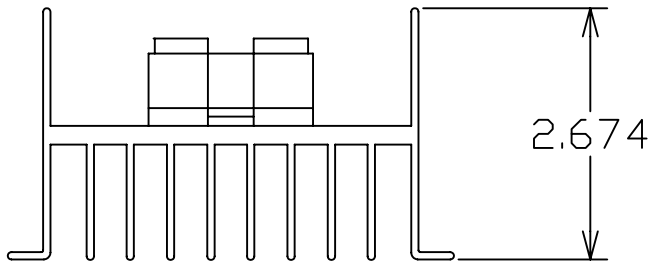
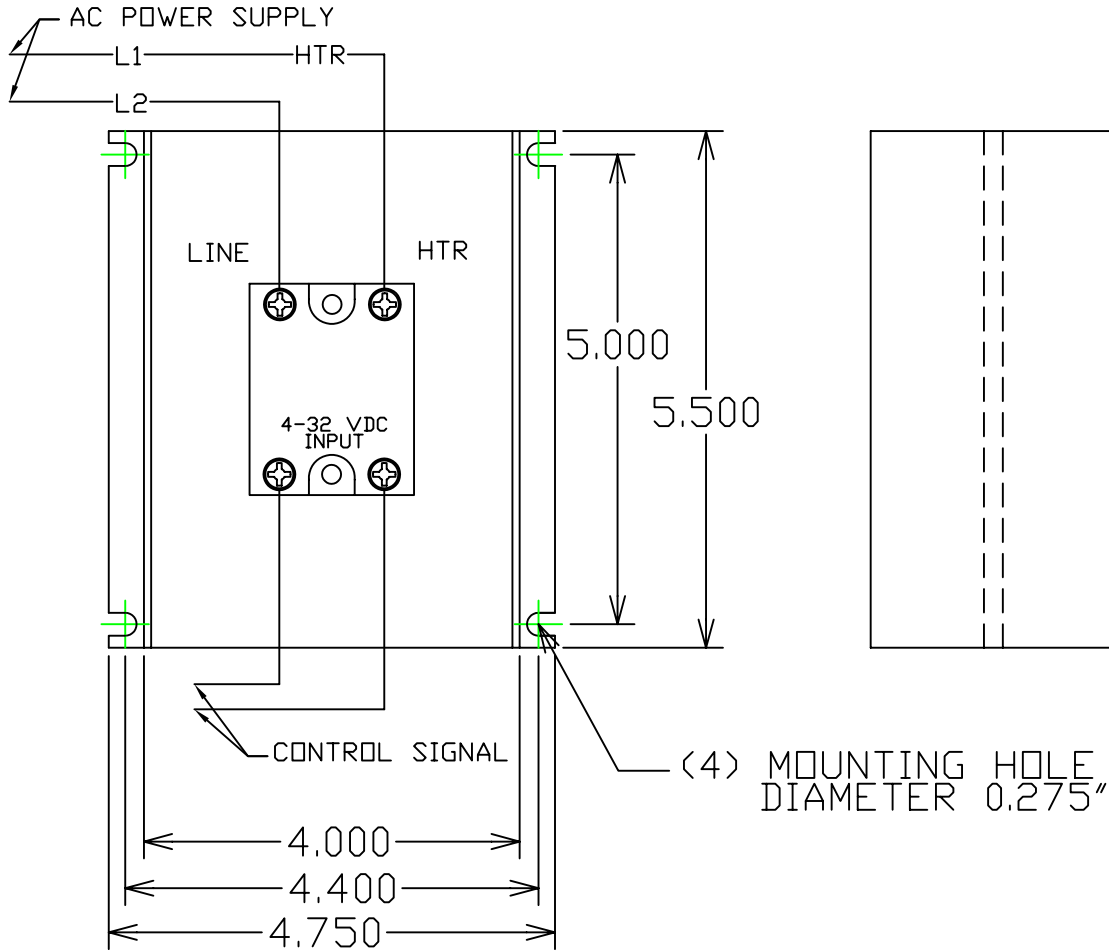

PHYSICAL DIMENSIONS and WIRING DIAGRAM

R1 - 15 & 25 AMP -120 OPTION

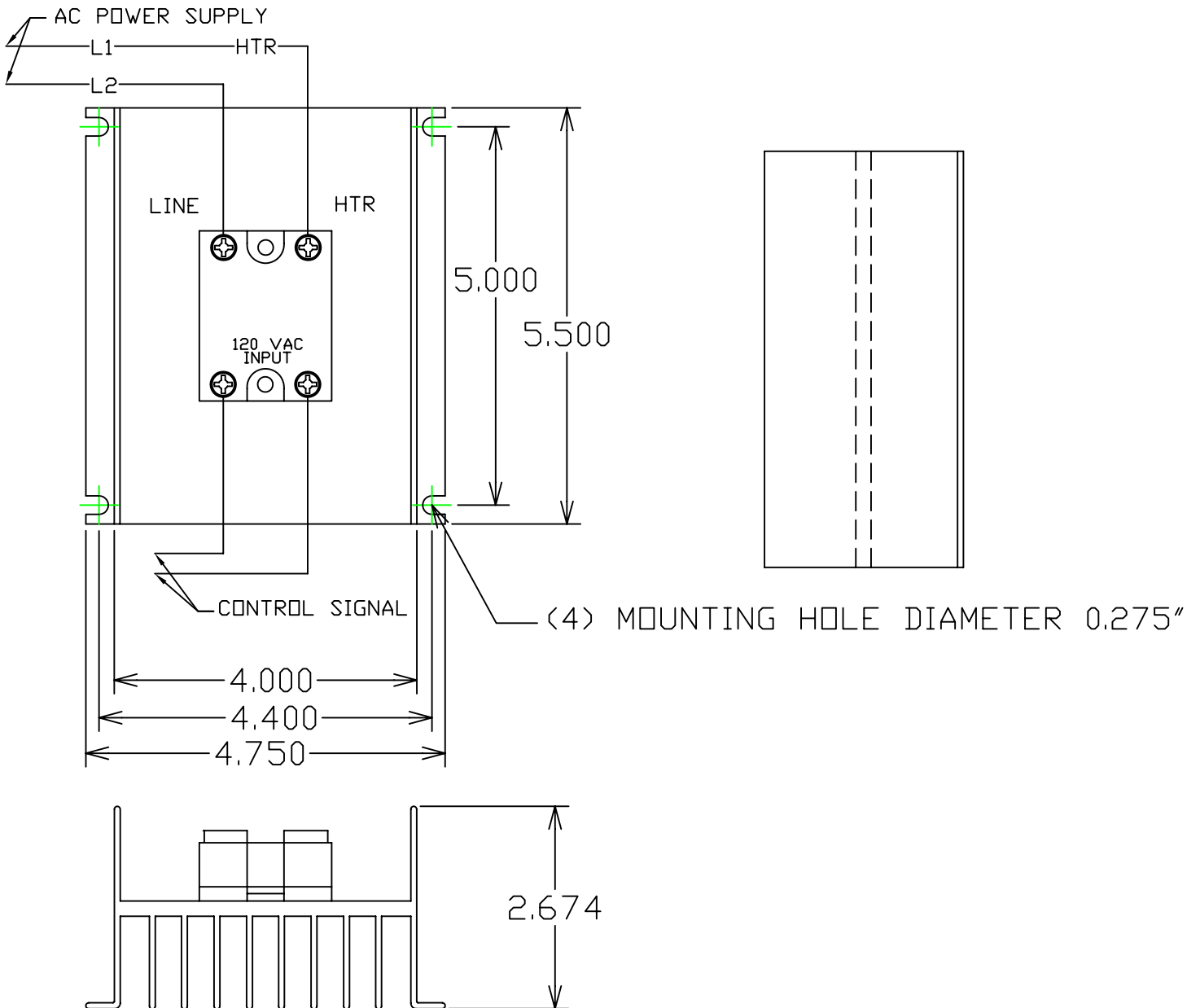

PHYSICAL DIMENSIONS and WIRING DIAGRAM

R2 - 15, 25 & 40 AMP

3-PHASE, 2 LEG CONTROL

DELTA OR WYE
3 WIRE LOAD

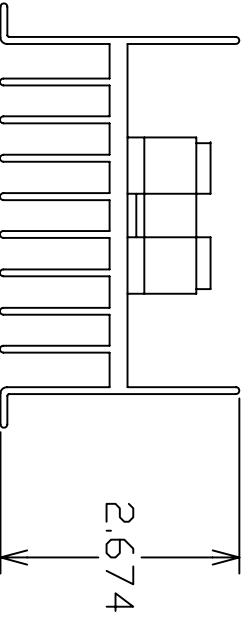
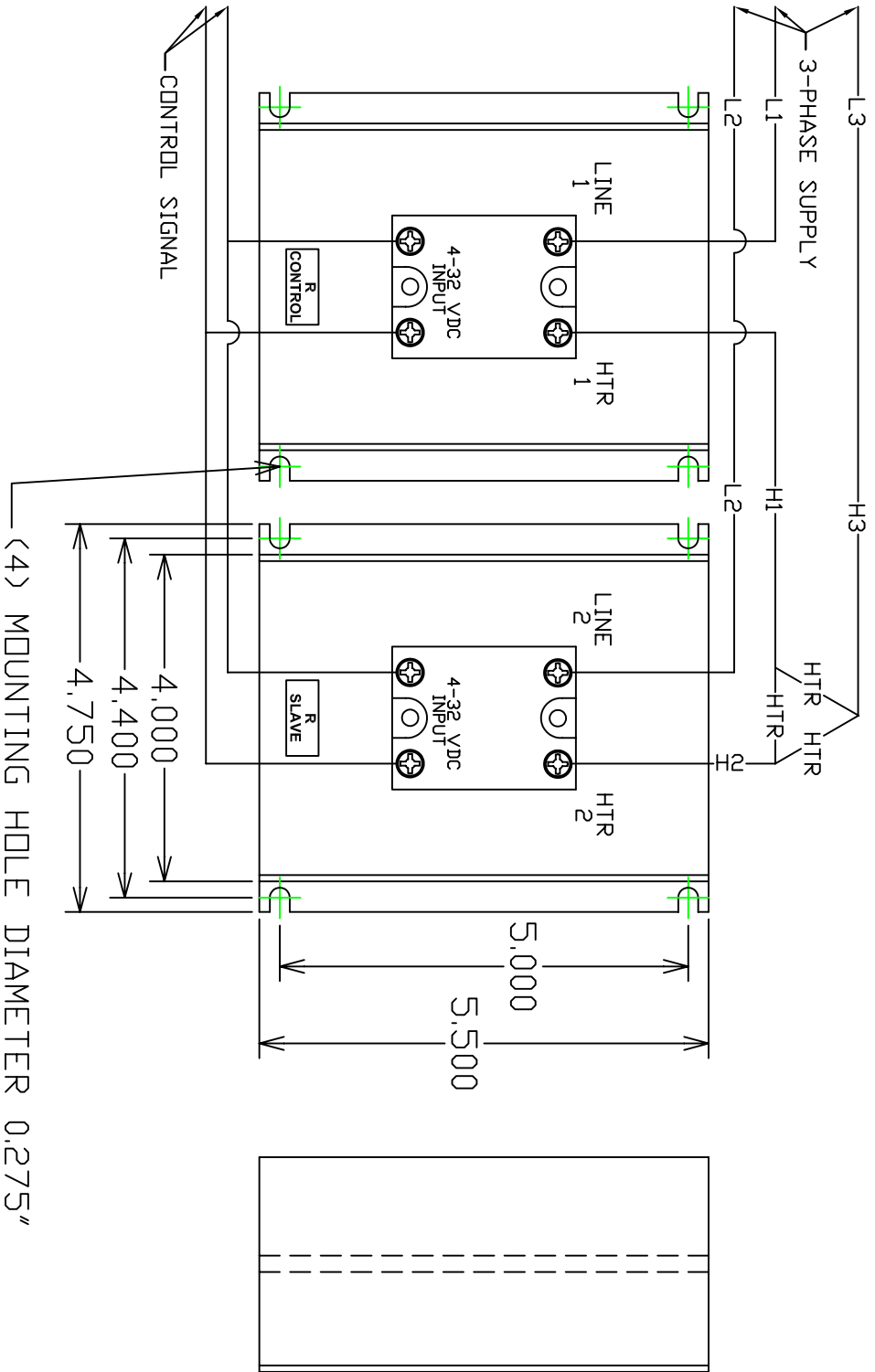

PHYSICAL DIMENSIONS and WIRING DIAGRAM

R2 - 15, 25 & 40 AMP -120 OPTION

3-PHASE, 2 LEG CONTROL

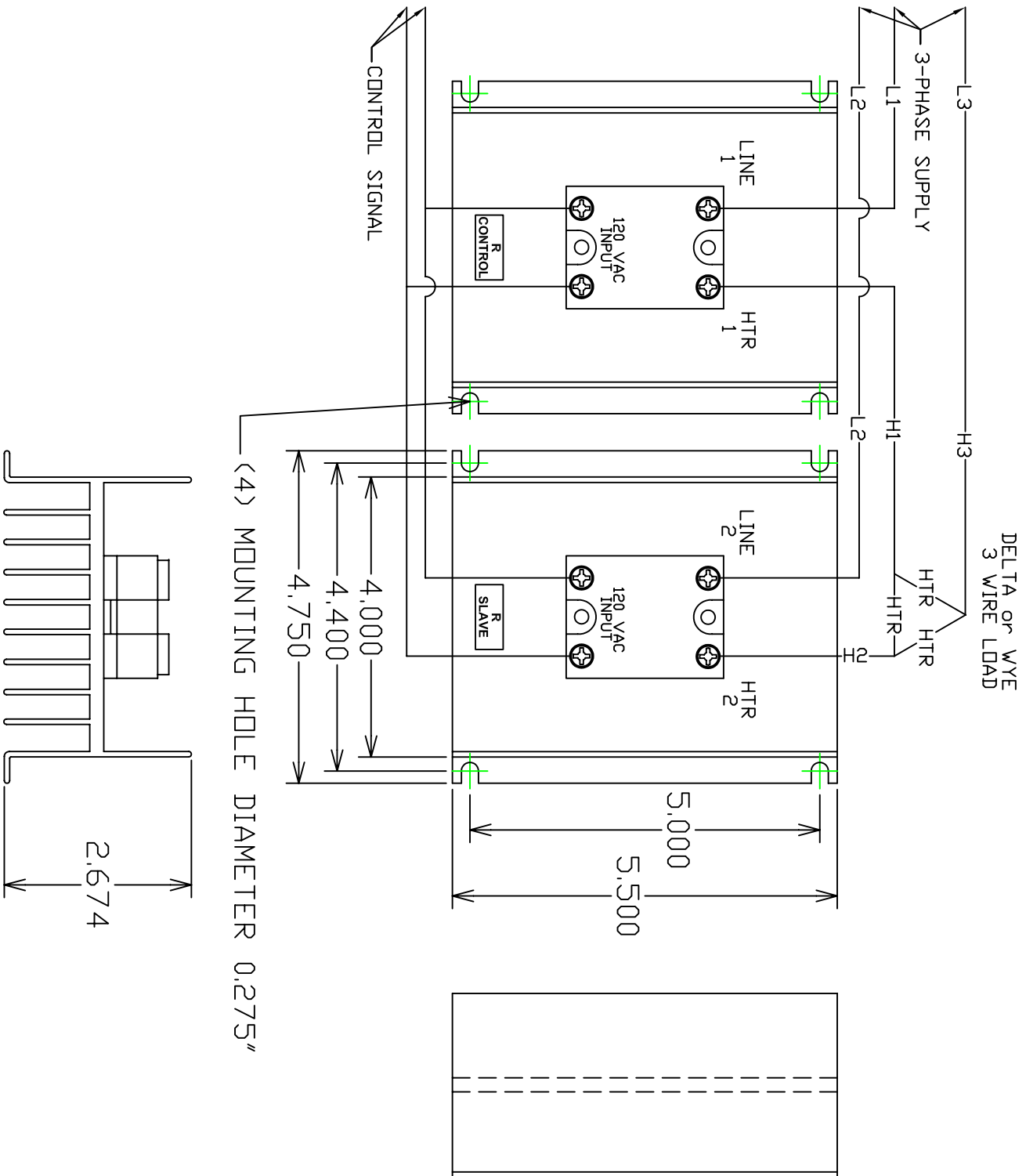

PHYSICAL DIMENSIONS and WIRING DIAGRAM

R2 - 30 AMP -TH (THRU-HOLE MOUNT)
3-PHASE, 2 LEG CONTROL

DELTA or WYE
3 WIRE LOAD

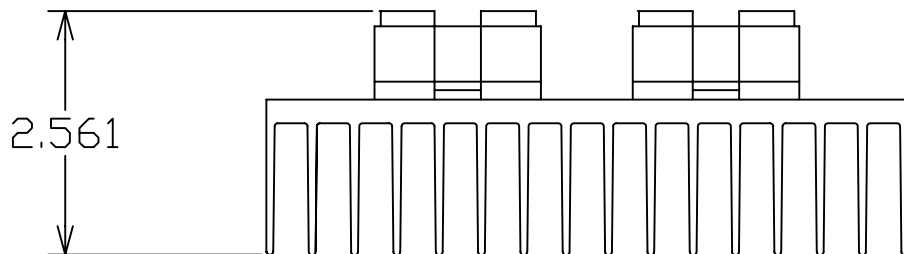
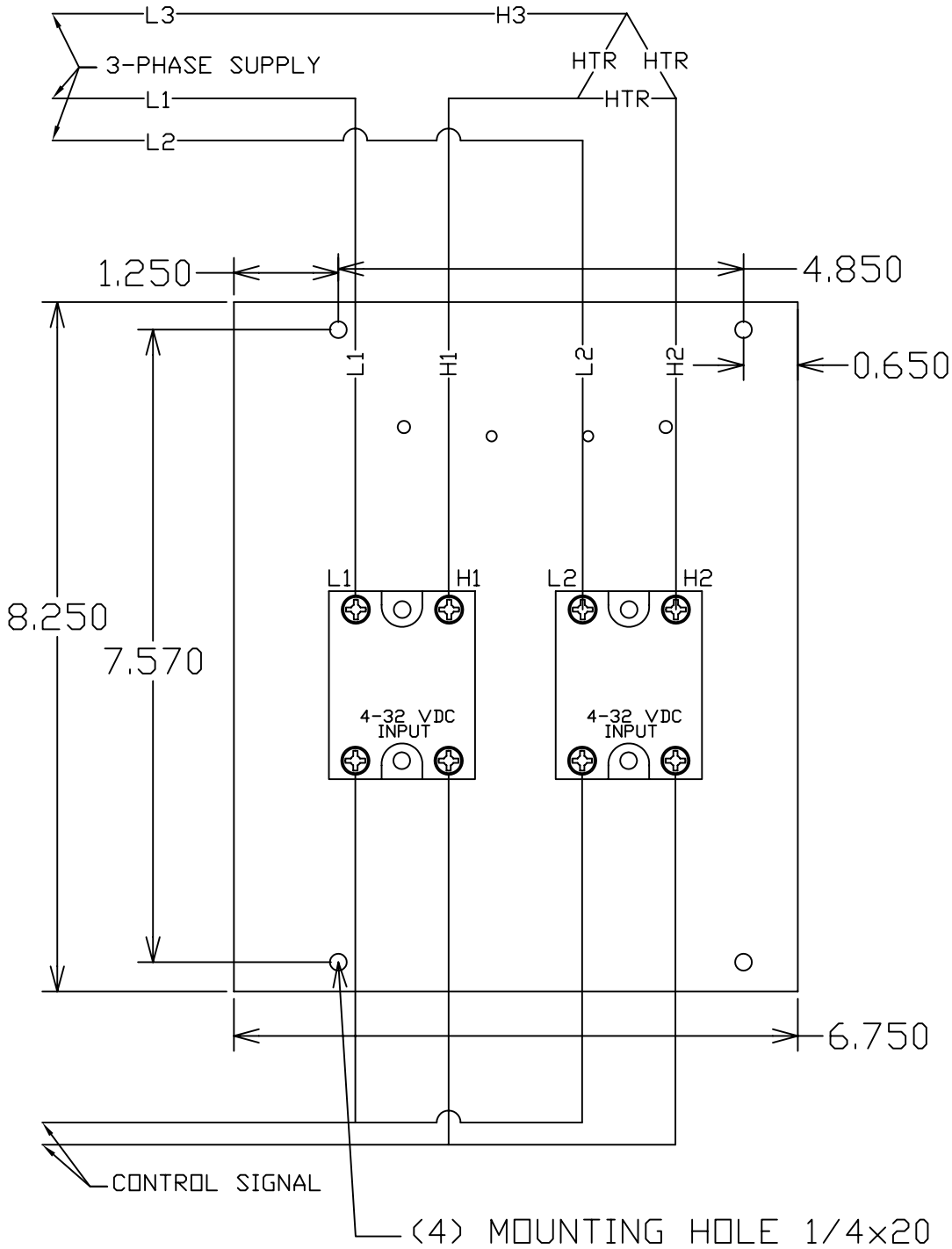

PHYSICAL DIMENSIONS and WIRING DIAGRAM

R2 - 30 AMP -TH (THRU-HOLE MOUNT) -120 OPTION

3-PHASE, 2 LEG CONTROL

DELTA or WYE
3 WIRE LOAD

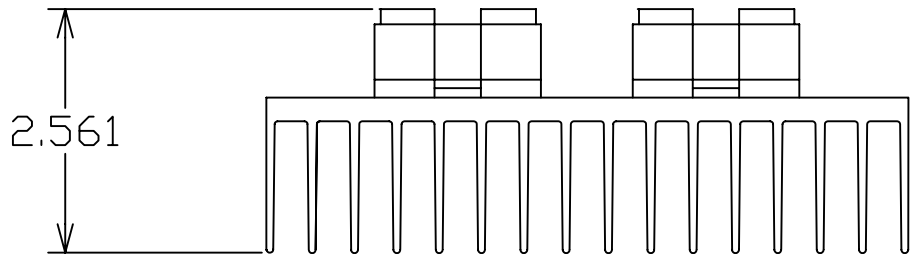
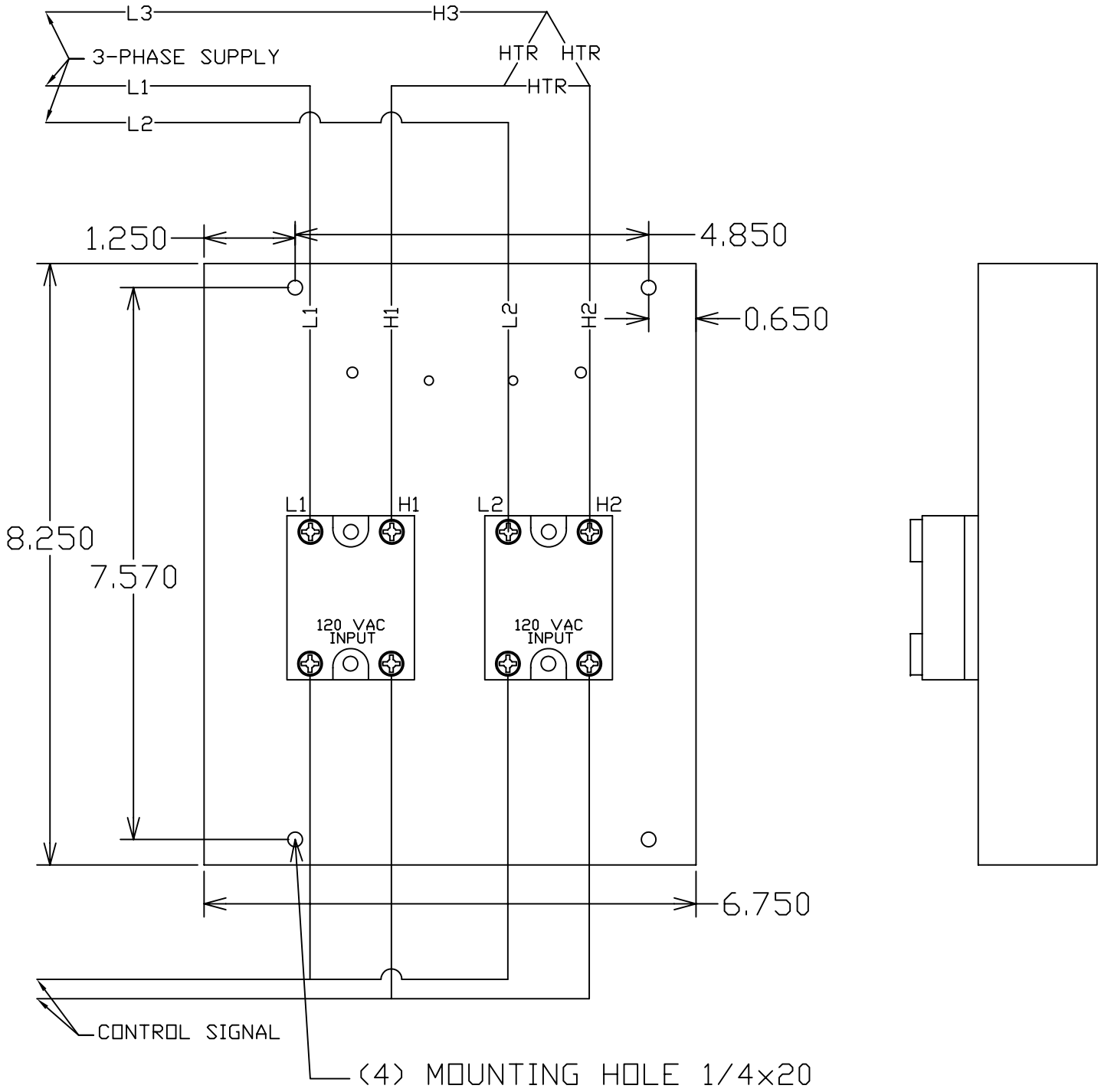

PHYSICAL DIMENSIONS and WIRING DIAGRAM

R3 - 15, 25 & 40 AMP

3-PHASE, 3 LEG CONTROL

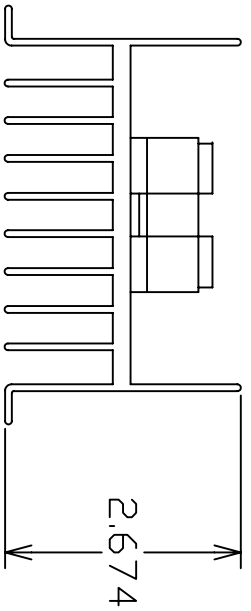
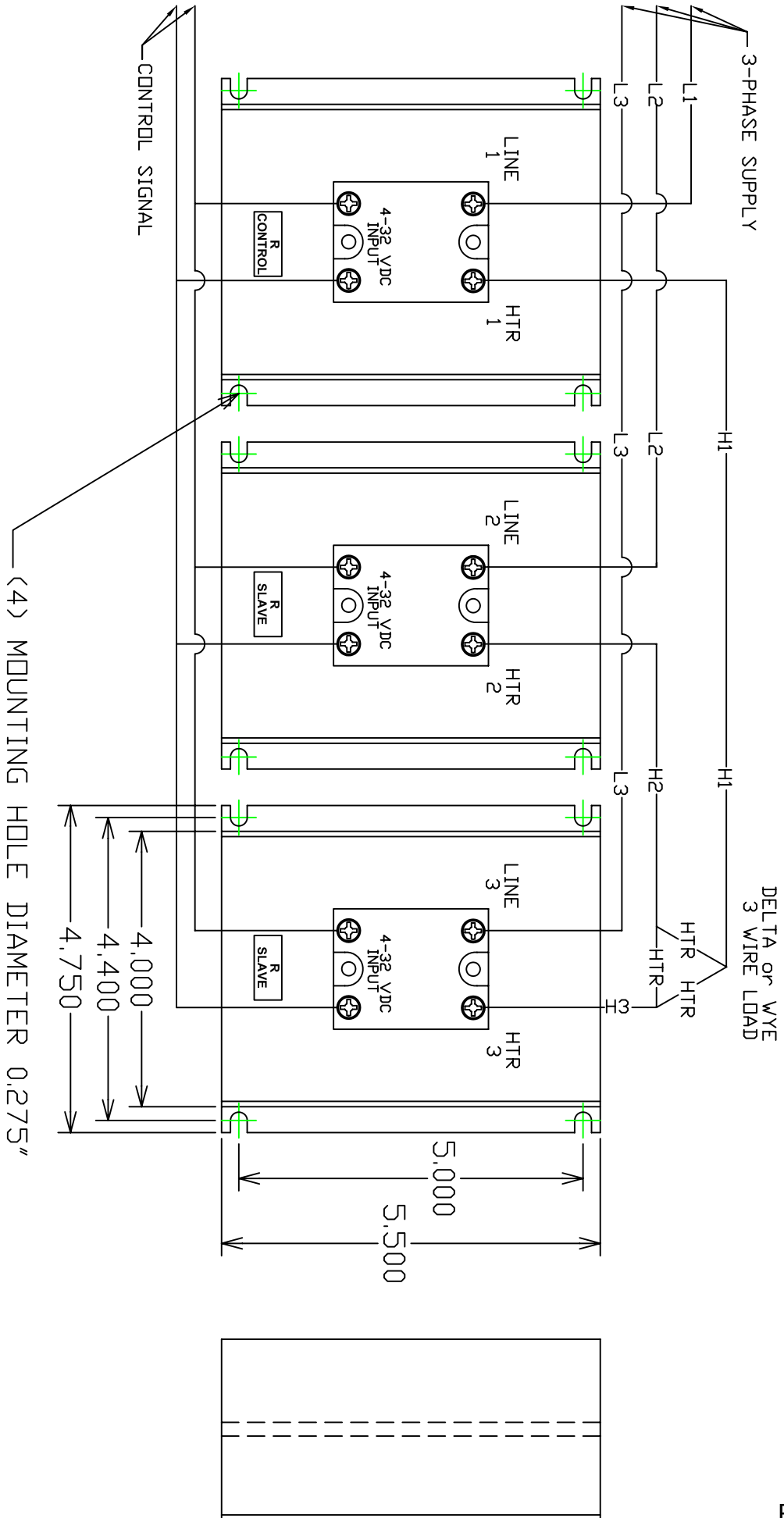

PHYSICAL DIMENSIONS and WIRING DIAGRAM

R3 - 15, 25 & 40 AMP -120 OPTION

3-PHASE, 3 LEG CONTROL

